



MYJG-60W Laser Power Supply Instruction Manual

[Home](#) » [Laser](#) » MYJG-60W Laser Power Supply Instruction Manual 

Contents

- [1 MYJG-60W Laser Power Supply](#)
- [2 Quality Assurance Testing](#)
- [3 Specifications](#)
- [4 Overall Diagram](#)
- [5 Documents / Resources](#)
 - [5.1 References](#)
- [6 Related Posts](#)

MYJG

MYJG-60W Laser Power Supply



With its high efficiency, frequency, and speed, this power supply is an essential part of your laser engraver,

converting standard power into the high-voltage power needed for your laser tube. The lightweight, compact MYJG-60W laser power supply is easy to operate. It is highly compatible with a variety of 60W CO₂ lasers, including both active-high and active-low machines. Its half-bridge soft switching capability improves efficiency and response. It automatically inspects your laser signal and water cooling system and works without similar devices' usual heat-generating heavy ballast resistance. This laser power supply connects directly to your system and includes standard installation holes. Using it ensures quick operation and maximizes the performance of your laser device, extending its service life.

Quality Assurance Testing

This device has undergone rigorous quality-assurance testing:

- It has been tested to withstand a minute of 1500V AC power at ≤ 10 mA.
- It has been found safe with ≥ 50 M Ω of resistance at 500V DC power.
- It has been tested to operate at capacity for 12 hours at 140°F (60°C).
- It has been turned on and off 500 times in ≤ 7 seconds.
- It has been shaken in every direction ± 0.5 mm 10–55 times a second for 2 hours.
- The ground wire has been found to carry a current of ≤ 0.5 mA when this device is used with 110V AC power and ≤ 1 mA when used with 220V AC power.
- Identical devices have shown a mean time before failure of 30,000 hours' use .

Specifications

- Input Power: 110V or 220V AC, 47–440 Hz, 60W
- Output Power: ≤ 28 kV DC, ≤ 30 mA
- Conversion Efficiency: 91%
- Dimensions: 7.8" \times 6.3" \times 3.6" (197 \times 161 \times 91 mm)
- Net Weight: 4.6 lb. (2.1 kg)

Warnings

- ONLY install/remove this device when all power to your engraver is turned off & cut. • <5 min. ensure that your engraver is properly grounded for normal operation. Use only with engraving machines that employ a three-prong plug with with a ground terminal. Use with an EMI filter is recommended.
- Be careful that the positive and negative output terminals are properly connected to the proper poles of your laser device prior to use. Be extremely careful around the high-voltage anode wire and its connections.

Cathode Connection
(white wire)



Anode Connection
(red wire)

- Ensure that your CO₂ laser's water cooling system is operating properly during use. In systems equipped with a protective sensor in their water system, this power supply will automatically cut off power to the laser if a

malfunction is detected by the circuit. In systems without such a circuit, however, the water cooling system is no less important and its proper operation should be manually ensured prior to each use.

- Just like your CO₂ laser, this power supply should be kept in a room with environmental control to ensure proper operation. The acceptable temperature range for this device is -22 to 149°F (-30 to 65°C). The acceptable humidity is $\leq 85\%$.

Overall Diagram

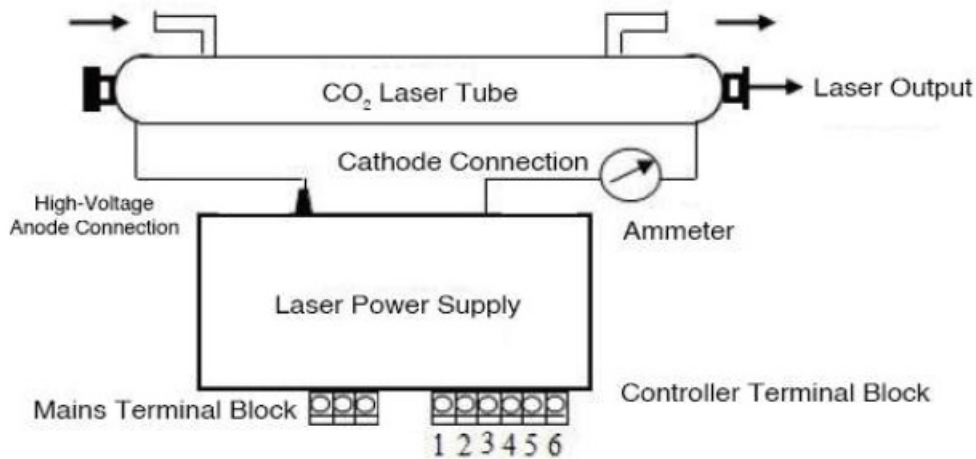

Terminals

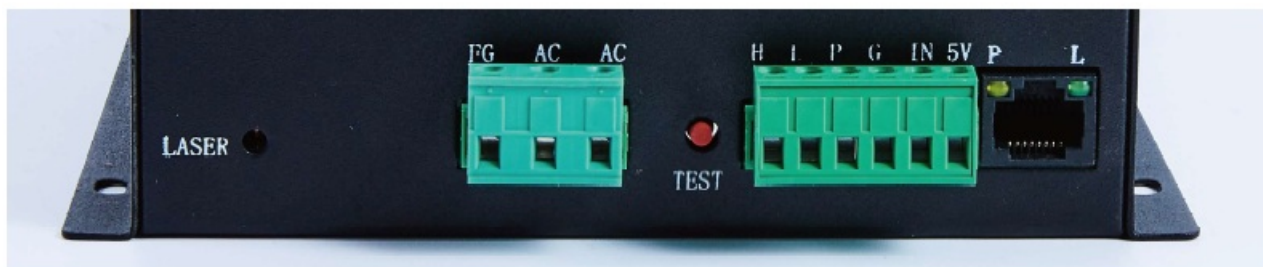

FG AC AC H L P G IN 5V

The first bank is a screw terminal block that connects your laser power supply to the power input from your home or business's main power. If you are assembling your laser, you will need to install the wiring correctly yourself. Place the wires into the proper slot & tighten them into place with the block's built-in screws. If this is a compatible replacement part, you can simply plug in the old terminal block. If this is a replacement part for a device that formerly had four slots in this location, the laser return wire from the cathode is instead located on the rear of this device; the other three wires should still be in the same order:

- FG: Ground Wire for the Mains & Case
- AC1: Neutral Wire to 110/220V Power
- AC2: Live Input from 110/220V Power

The second connects your laser power supply to the engraver's control system. Just like the first bank, if you have an identical one already set up, you can simply plug in your old screw terminal block directly. Otherwise, take care to install the wiring correctly. Use of separately colored wiring is recommended.

- H: Connection for Active-High Devices
- L: Connection for Active-Low Devices
- P: Line to the Laser Trigger, Water & Other Systems (such as a door switch)

- G: Ground Wire for the Control System, PWM Level Shifters, Potentiometers, etc.
- IN: Input Power for PWM Level Shifters or Potentiometers
- 5V: 5V Connection for Digital Signals

In the event that your laser is powered but fails to fire, the Test Button can be used to see if the problem lies with the display panel, controller, or their wiring (if it successfully fires a test beam) or if the problem lies with the power supply or its connection to the laser (if the laser fails to fire). In the event of a problem with the power supply or connection, contact customer service.

CONTACT US

Thank you for choosing our products! If you have any questions or comments, contact us at help@cs-supportpro.com and we'll resolve your issue ASAP For a .pdf copy of the latest version of these instructions, use the appropriate app on your smartphone to scan the QR code to the right

Documents / Resources

 <p>MYJG-60W Laser Power Supply Instruction Manual</p>	<p>LASER MYJG-60W Laser Power Supply [pdf] Instruction Manual MYJG-60W Laser Power Supply, MYJG-60W, Laser Power Supply</p>
---	---

References

-  [Transparent outsourced web hosting tech support |SupportPRO](#)