

WT32-S1 WiFi Module

Extreme / Open / Small / Easy

Specification

Version 1.1

2019/02/25

Disclaimer and Copyright Notice

Information in this document, including URL references, is subject to change without notice.

THIS DOCUMENT IS PROVIDED AS IS WITH NO WARRANTIES WHATSOEVER, INCLUDING ANY WARRANTY OF MERCHANTABILITY, NON-INFRINGEMENT, FITNESS FOR ANY PARTICULAR PURPOSE, OR ANY WARRANTY OTHERWISE ARISING OUT OF ANY PROPOSAL, SPECIFICATION OR SAMPLE. All liability, including liability for infringement of any proprietary rights, relating to use of information in this document is disclaimed. No licenses express or implied, by estoppel or otherwise, to any intellectual property rights are granted herein.

The WiFi Alliance Member Logo is a trademark of the WiFi Alliance.

All trade names, trademarks and registered trademarks mentioned in this document are property of their respective owners, and are hereby acknowledged.

Note

As the product upgrade or other reasons, this manual may change. Shenzhen Wireless-Tag Technology Co., Ltd has right to modify the contents of this manual without any notice or warning. This manual is only as a guide, Wireless-Tag Technology Co., Ltd Spare no effort to provide accurate information in this manual, but the Wireless-Tag can't guarantee manual there is no problem, all statements in this manual, information and suggestions do not constitute any guarantee of express or implication.

Amendment record

Version	Changed by	Time	Reason	Details
V1.0	Louie	2017.12.13	Original	
V1.1	Louie	2019.02.25	Original	Add Flash memory size

Contents

1. Overview	- 5 -
2. Main Features.....	- 5 -
3. Hardware Specifications.....	- 7 -
3.1 Pin Description.....	- 7 -
3.1.1 Strapping Pins.....	- 8 -
3.2 Functional Description.....	- 10 -
3.2.1 CPU and Internal Memory.....	- 10 -
3.2.2 Low-Power Management	- 10 -
Note:	- 11 -
3.3 Peripherals and Sensors	- 12 -
3.4 Electrical Characteristic.....	- 16 -
3.4.1 Maximum Ratings.....	- 16 -
3.4.2 Recommended Operating Environment	- 17 -
3.4.3 Digital Port Characteristics	- 17 -
3.5 RF Characteristics	- 17 -
3.5.1 Wi-Fi Radio.....	- 17 -
3.5.2 BLE Radio	- 18 -
4. Mechanical Dimensions.....	- 19 -
4.1 Module Size	- 19 -
4.2 Schematics.....	- 20 -
5. Product Trial.....	- 20 -

1. Overview

WT32-S1 WiFi module is designed by Wireless-Tag, low consumption, cost-effective embedded wireless network control module. It can meet the IoT application requirements in the smart power grids, building automation, security and protection, smart home, remote health care etc.

The module's core processor is the ESP32, that is a single-chip solution that integrates dual-mode 2.4 GHz Wi-Fi and Bluetooth in a smaller package size, using TSMC's ultra-low power 40-nanometer process with an integrated antenna switch, RF Balun, power amplifier, low noise amplifier, filter and power management module. ESP32 also integrates a wealth of peripherals, including capacitive touch sensors, Hall sensors, low-noise sense amplifier, SD card interface, Ethernet interface, high-speed SDIO / SPI, UART, I2S and I2C.

ESP32 chip integrates traditional Bluetooth, Bluetooth low energy and Wi-Fi, has a wide range of uses: Wi-Fi supports a wide range of communication connections, also supports direct connection to the Internet through a router; and Bluetooth allows users to connect mobile phones or broadcast BLE Beacon for signal detection. ESP32 chip sleep current less than 5 μ A, making it suitable for battery-powered wearable electronic devices. ESP32's operating system is freeRTOS with LWIP, and built-in TLS 1.2 with hardware acceleration. The chip also supports OTA encryption upgrade, developers can continue to upgrade after the release of the product.

2. Main Features

WT32-S1 Specifications Table 1

Table-1 Specifications

Categories	Items	Specifications
Wi-Fi	RF certification	FCC/CE/RoHS
	Protocols	802.11 b/g/n/e/i (802.11n up to 150 Mbps) A-MPDU and A-MSDU aggregation and 0.4 μ s guard interval support
	Frequency range	2.4~2.5 GHz
Bluetooth	Protocols	Bluetooth v4.2 BR/EDR and BLE specification
	Radio	NZIF receiver with -97 dBm sensitivity
		Class-1, class-2 and class-3 transmitter
	Audio	AFH CVSD and SBC
Hardware	Module interface	SD card, UART, SPI, SDIO, I2C, LED PWM, Motor PWM, I2S, IR
		GPIO, capacitive touch sensor, ADC, DAC, LNA preamplifier
	On-board Flash Memory	32Mbit

	On-chip sensor	Hall sensor, temperature sensor
	On-board clock	40 MHz crystal
	Operating voltage/Power supply	2.7~3.6V
	Operating current	Average: 80 mA
	Minimum current delivered by power supply	500 mA
	Operating temperature range	-40°C~+85°C
	Ambient temperature range	Normal temperature
	Package size	22.5mm x16mm x3.5mm(±0.2mm)
Software	Wi-Fi mode	Station/softAP/SoftAP+station/P2P
	Wi-Fi Security	WPA/WPA2/WPA2-Enterprise/WPS
	Encryption	AES/RSA/ECC/SHA
	Firmware upgrade	UART Download / OTA (download and write firmware via network or host)
	Software development	Supports Cloud Server Development / SDK for custom firmware development
	Network protocols	IPv4,IPv6,SSL,TCP/UDP/HTTP/FTP/MQTT
	User configuration	AT instruction set, cloud server, Android/iOS app

3. Hardware Specifications

3.1 Pin Description

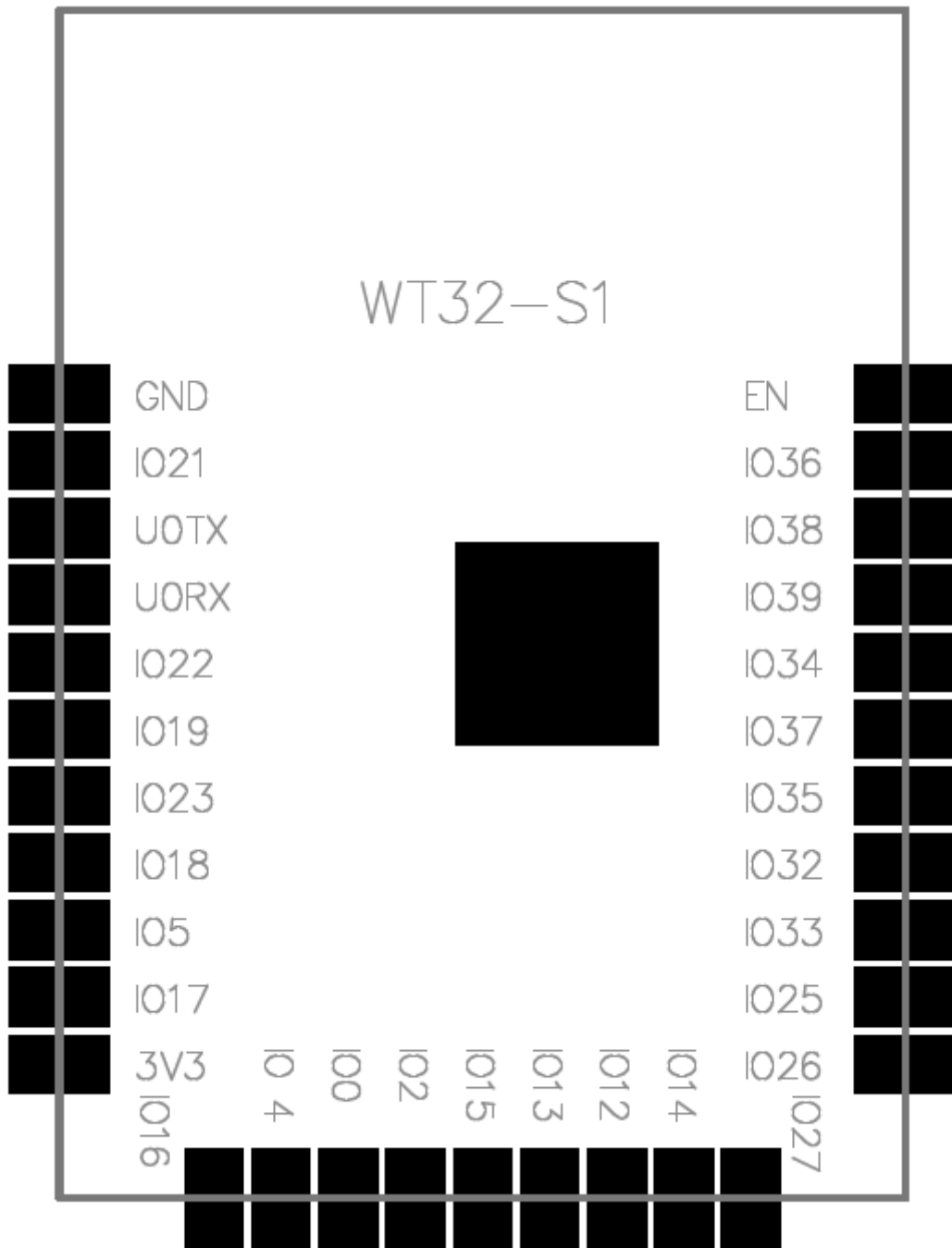

Figure-1 WT32-S1 Pinout (Bottom View)

Table-2 Pin Definition and Description

No.	Name	Function
1	EN	Chip-enable signal. Active high.
2	I036	GPI36, SENSOR_VP, ADC_H, ADC1_CH0, RTC_GPIO0
3	I038	GPI38, SENSOR_CAPN, ADC_H, ADC1_CH2, RTC_GPIO2

4	IO39	GPI39, SENSOR_VN, ADC_H, ADC1_CH3, RTC_GPIO3
5	IO34	GPI34, ADC1_CH6, RTC_GPIO4
6	IO37	GPI37, SENSOR_CAPP, ADC_H, ADC1_CH1, RTC_GPIO1
7	IO35	GPI35, ADC1_CH7, RTC_GPIO5
8	IO32	GPIO32, XTAL_32K_P (32.768 kHz crystal oscillator input), ADC1_CH4, TOUCH9, RTC_GPIO9
9	IO33	GPIO33, XTAL_32K_N (32.768 kHz crystal oscillator output), ADC1_CH5, TOUCH8, RTC_GPIO8
10	IO25	GPIO25, DAC_1, ADC2_CH8, RTC_GPIO6, EMAC_RXD0
11	IO26	GPIO26, DAC_2, ADC2_CH9, RTC_GPIO7, EMAC_RXD1
12	IO27	GPIO27, ADC2_CH7, TOUCH7, RTC_GPIO17, EMAC_RX_DV
13	IO14	GPIO14, ADC2_CH6, TOUCH6, RTC_GPIO16, MTMS, HSPICLK, HS2_CLK, SD_CLK, EMAC_TXD2
14	IO12	GPIO12, ADC2_CH5, TOUCH5, RTC_GPIO15, MTDI, HSPIQ, HS2_DATA2, SD_DATA2, EMAC_TXD3
15	IO13	GPIO13, ADC2_CH4, TOUCH4, RTC_GPIO14, MTCK, HSPID, HS2_DATA3, SD_DATA3, EMAC_RX_ER
16	IO15	GPIO15, ADC2_CH3, TOUCH3, MTDO, HSPICS0, RTC_GPIO13, HS2_CMD, SD_CMD, EMAC_RXD3
17	IO2	GPIO2, ADC2_CH2, TOUCH2, RTC_GPIO12, HSPIWP, HS2_DATA0, SD_DATA0
18	IO0	GPIO0, ADC2_CH1, TOUCH1, RTC_GPIO11, CLK_OUT1, EMAC_TX_CLK
19	IO4	GPIO4, ADC2_CH0, TOUCH0, RTC_GPIO10, HSPIHD, HS2_DATA1, SD_DATA1, EMAC_TX_ER
20	IO16	GPIO16, HS1_DATA4, U2RXD, EMAC_CLK_OUT
21	3V3	Power supply.
22	IO17	GPIO17, HS1_DATA5, U2TXD, EMAC_CLK_OUT_180
23	IO5	GPIO5, VSPICS0, HS1_DATA6, EMAC_RX_CLK
24	IO18	GPIO18, VSPICLK, HS1_DATA7
25	IO23	GPIO23, VSPID, HS1_STROBE
26	IO19	GPIO19, VSPIQ, U0CTS, EMAC_TXD0
27	IO22	GPIO22, VSPIWP, U0RTS, EMAC_TXD1
28	U0RXD	GPIO3, U0RXD, CLK_OUT2
29	U0TXD	GPIO1, U0TXD, CLK_OUT3, EMAC_RXD2
30	IO21	GPIO21, VSPIHD, EMAC_TX_EN
31	GND	Ground

3.1.1 Strapping Pins

ESP32 has five strapping pins, which can be seen in Section 6 Schematics:

- MTDI

- GPIO0
- GPIO2
- MTDO
- GPIO5

Software can read the value of these five bits from the register "GPIO_STRAPPING".

During the chip's system reset (power-on reset, RTC watchdog reset and brownout reset), the latches of the strapping pins sample the voltage level as strapping bits of "0" or "1", and hold these bits until the chip is powered down or shut down. The strapping bits configure the device boot mode, the operating voltage of VDD_SDIO and other system initial settings.

Each strapping pin is connected with its internal pull-up/pull-down during the chip reset. Consequently, if a strapping pin is unconnected or the connected external circuit is high-impedance, the internal weak pull-up/pull-down will determine the default input level of the strapping pins.

To change the strapping bit values, users can apply the external pull-down/pull-up resistances, or apply the host MCU's GPIOs to control the voltage level of these pins when powering on ESP32.

After reset, the strapping pins work as the normal functions pins.

Refer to Table 3 for detailed boot modes' configuration by strapping pins.

Table-3 Strapping Pins

Voltage of Internal LDO (VDD_SDIO)					
Pin	Default	3.3V	1.8V		
MTDI/GPIO12	Pull-down	0	1		
Booting Mode					
Pin	Default	SPI Boot	Download Boot		
GPIO0	Pull-up	1	0		
GPIO2	Pull-down	Don't-care	0		
Debugging Log on U0TXD During Booting					
Pin	Default	U0TXD Toggling	U0TXD Silent		
MTDO/GPIO15	Pull-up	1	0		
Timing of SDIO Slave					
Pin	Default	Falling-edge Input Falling-edge Output	Falling-edge Input Rising-edge Output	Rising-edge Input Falling-edge Output	Rising-edge Input Rising-edge Output
MTDO	Pull-up	0	0	1	1
GPIO5	Pull-up	0	1	0	1

3.2 Functional Description

3.2.1 CPU and Internal Memory

ESP32-D0WDQ6 contains two low-power Xtensa® 32-bit LX6 microprocessors. The internal memory includes:

- 448 kB of ROM for booting and core functions.
- 520 kB (8 kB RTC FAST Memory included) of on-chip SRAM for data and instruction.
- 8 kB of SRAM in RTC, which is called RTC FAST Memory and can be used for data storage; it is accessed by the main CPU during RTC Boot from the Deep-sleep mode.
- 8 kB of SRAM in RTC, which is called RTC SLOW Memory and can be accessed by the co-processor during the Deep-sleep mode.
- 1 kbit of eFuse, of which 256 bits are used for the system (MAC address and chip configuration) and the remaining 768 bits are reserved for customer applications, including Flash-Encryption and Chip-ID.

3.2.2 Low-Power Management

With the use of advanced power management technologies, ESP32 can switch between different power modes.

• Power modes

- Active mode: The chip radio is powered on. The chip can receive, transmit, or listen.
- Modem-sleep mode: The CPU is operational and the clock is configurable. The Wi-Fi/Bluetooth baseband and radio are disabled.
- Light-sleep mode: The CPU is paused. The RTC memory and RTC peripherals, as well as the ULP co-processor are running. Any wake-up events (MAC, host, RTC timer, or external interrupts) will wake up the chip.
- Deep-sleep mode: Only the RTC memory and RTC peripherals are powered on. Wi-Fi and Bluetooth connection data are stored in the RTC memory. The ULP co-processor can work.
- Hibernation mode: The internal 8-MHz oscillator and ULP co-processor are disabled. The RTC recovery memory is powered down. Only one RTC timer on the slow clock and some RTC GPIOs are active. The RTC timer or the RTC GPIOs can wake up the chip from the Hibernation mode.

• Sleep Patterns

- Association sleep pattern: The power mode switches between the Active mode, Modem- and Lightsleep

mode during this sleep pattern. The CPU, Wi-Fi, Bluetooth, and radio are woken up at predetermined intervals to keep Wi-Fi/BT connections alive.

- ULP sensor-monitored pattern: The main CPU is in the Deep-sleep mode. The ULP co-processor takes sensor measurements and wakes up the main system, based on the data collected from sensors.

Table-4 Functionalities Depending on the Power Modes

Power mode	Active	Modem-sleep	Light-sleep	Deep-sleep	Hibernation
Sleep mode	Association sleep pattern			ULP sensor-monitored pattern	-
CPU	ON	ON	PAUSE	OFF	OFF
Wi-Fi/BT baseband and radio	ON	OFF	OFF	OFF	OFF
RTC memory and RTC peripherals	ON	ON	ON	ON	OFF
ULP co-processor	ON	ON	ON	ON /OFF	OFF

Table-5 Power Consumption by Power Modes

Power mode	Description	Power consumption
Modem-sleep	The CPU is powered on.	Max speed 240 MHz: 30 mA ~ 50 mA
		Normal speed 80 MHz: 20 mA ~ 25 mA
		Slow speed 2 MHz: 2 mA ~ 4 mA
Light-sleep	-	0.8 mA
Deep-sleep	The ULP co-processor is powered on.	150 μ A
	ULP sensor-monitored pattern	100 μ A @1% duty
	RTC timer + RTC memory	10 μ A
Hibernation	RTC timer only	5 μ A
Power off	CHIP_PU is set to low level, the chip is powered off	0.1 μ A

Note:

- In Modem-sleep mode, the CPU frequency changes automatically. The frequency depends on the CPU load and the peripherals used.
- During Deep-sleep, when the ULP co-processor is powered on, peripherals such as GPIO and I2C are able to work.
- When the system works in the ULP sensor-monitored pattern, the ULP co-processor works with the ULP sensor periodically; ADC works with a duty cycle of 1%, so the power consumption is 100 μ A.

3.3 Peripherals and Sensors

Table-6 Description of Peripherals and Sensors

Interface	Signal	Pin	Function
ADC	ADC1_CH0	SENSOR_VP	Two 12-bit SAR ADCs
	ADC1_CH3	SENSOR_VN	
	ADC1_CH4	IO32	
	ADC1_CH5	IO33	
	ADC1_CH6	IO34	
	ADC1_CH7	IO35	
	ADC2_CH0	IO4	
	ADC2_CH1	IO0	
	ADC2_CH2	IO2	
	ADC2_CH3	IO15	
	ADC2_CH4	IO13	
	ADC2_CH5	IO12	
	ADC2_CH6	IO14	
	ADC2_CH7	IO27	
	ADC2_CH8	IO25	
ADC2_CH9	IO26		
Ultra-Low Noise Analog Pre-Amplifier	SENSOR_VP	IO36	Provides about 60 dB gain by using larger capacitors on PCB
	SENSOR_VN	IO39	
DAC	DAC_1	IO25	Two 8-bit DACs
	DAC_2	IO26	
Touch Sensor	TOUCH0	IO4	Capacitive touch sensors
	TOUCH1	IO0	
	TOUCH2	IO2	
	TOUCH3	IO15	
	TOUCH4	IO13	
	TOUCH5	IO12	
	TOUCH6	IO14	
	TOUCH7	IO27	
	TOUCH8	IO33	
	TOUCH9	IO32	

Interface	Signal	Pin	Function
SD/SDIO/MMC Host Controller	HS2_CLK	MTMS	Supports SD memory card V3.01 standard
	HS2_CMD	MTDO	
	HS2_DATA0	IO2	
	HS2_DATA1	IO4	
	HS2_DATA2	MTDI	
	HS2_DATA3	MTCK	
Motor PWM	PWM0_OUT0~2	Any GPIOs	Three channels of 16-bit timers generate PWM waveforms. Each channel has a pair of output signals, three fault detection signals, three event-capture signals, and three sync signals.
	PWM1_OUT_IN0~2		
	PWM0_FLT_IN0~2		
	PWM1_FLT_IN0~2		
	PWM0_CAP_IN0~2		
	PWM1_CAP_IN0~2		
	PWM0_SYNC_IN0~2		
	PWM1_SYNC_IN0~2		
LED PWM	ledc_hs_sig_out0~7	Any GPIOs	16 independent channels @80 MHz clock/RTC CLK. Duty accuracy: 16 bits.
	ledc_ls_sig_out0~7		
UART	U0RXD_in	Any GPIOs	Two UART devices with hardware flow-control and DMA
	U0CTS_in		
	U0DSR_in		
	U0TXD_out		
	U0RTS_out		
	U0DTR_out		
	U1RXD_in		
	U1CTS_in		
	U1TXD_out		
	U1RTS_out		
	U2RXD_in		
	U2CTS_in		
	U2TXD_out		
	U2RTS_out		

Interface	Signal	Pin	Function
I2C	I2CEXT0_SCL_in	Any GPIOs	Two I2C devices in slave or master modes
	I2CEXT0_SDA_in		
	I2CEXT1_SCL_in		
	I2CEXT1_SDA_in		
	I2CEXT0_SCL_out		
	I2CEXT0_SDA_out		
	I2CEXT1_SCL_out		
	I2CEXT1_SDA_out		
I2S	I2S0I_DATA_in0~15	Any GPIOs	Stereo input and output from/to the audio codec, and parallel LCD data output
	I2S0O_BCK_in		
	I2S0O_WS_in		
	I2S0I_BCK_in		
	I2S0I_WS_in		
	I2S0I_H_SYNC		
	I2S0I_V_SYNC		
	I2S0I_H_ENABLE		
	I2S0O_BCK_out		
	I2S0O_WS_out		
	I2S0I_BCK_out		
	I2S0I_WS_out		
	I2S0O_DATA_out0~23		
	I2S1I_DATA_in0~15		
	I2S1O_BCK_in		
	I2S1O_WS_in		
	I2S1I_BCK_in		
	I2S1I_WS_in		
	I2S1I_H_SYNC		
	I2S1I_V_SYNC		
	I2S1I_H_ENABLE		
	I2S1O_BCK_out		
	I2S1O_WS_out		
	I2S1I_BCK_out		
I2S1I_WS_out			
I2S1O_DATA_out0~23			
Remote Controller	RMT_SIG_IN0~7	Any GPIOs	Eight channels of IR transmitter and receiver for various waveforms
	RMT_SIG_OUT0~7		

Interface	Signal	Pin	Function
Parallel QSPI	SPIHD	SHD/SD2	Supports Standard SPI, Dual SPI, and Quad SPI that can be connected to the external flash and SRAM
	SPIWP	SWP/SD3	
	SPICS0	SCS/CMD	
	SPICLK	SCK/CLK	
	SPIQ	SDO/SD0	
	SPID	SDI/SD1	
	HSPICLK	IO14	
	HSPICS0	IO15	
	HSPIQ	IO12	
	HSPID	IO13	
	HSPIHD	IO4	
	HSPIWP	IO2	
	VSPICLK	IO18	
	VSPICS0	IO5	
	VSPIQ	IO19	
	VSPID	IO23	
VSPIHD	IO21		
VSPIWP	IO22		
General Purpose SPI	HSPIQ_in/_out	Any GPIOs	Standard SPI consists of clock, chip-select, MOSI and MISO. These SPIs can be connected to LCD and other external devices. They support the following features: <ul style="list-style-type: none"> • both master and slave modes; • 4 sub-modes of the SPI format transfer that depend on the clock phase (CPHA) and clock polarity (CPOL) control; • configurable SPI frequency; • up to 64 bytes of FIFO and DMA.
	HSPID_in/_out		
	HSPICLK_in/_out		
	HSPI_CS0_in/_out		
	HSPI_CS1_out		
	HSPI_CS2_out		
	VSPIQ_in/_out		
	VSPID_in/_out		
	VSPICLK_in/_out		
	VSPI_CS0_in/_out		
	VSPI_CS1_out		
	VSPI_CS2_out		
JTAG	MTDI	IO12	JTAG for software debugging
	MTCK	IO13	
	MTMS	IO14	
	MTDO	IO15	

Interface	Signal	Pin	Function
SDIO 从机	SD_CLK	IO6	SDIO interface that conforms to the industry standard SDIO 2.0 card specification.
	SD_CMD	IO11	
	SD_DATA0	IO7	
	SD_DATA1	IO8	
	SD_DATA2	IO9	
	SD_DATA3	IO10	
EMAC	EMAC_TX_CLK	IO0	Ethernet MAC with MII/RMII interface
	EMAC_RX_CLK	IO5	
	EMAC_TX_EN	IO21	
	EMAC_TXD0	IO19	
	EMAC_TXD1	IO22	
	EMAC_TXD2	IO14	
	EMAC_TXD3	IO12	
	EMAC_RX_ER	IO13	
	EMAC_RX_DV	IO27	
	EMAC_RXD0	IO25	
	EMAC_RXD1	IO26	
	EMAC_RXD2	TXD	
	EMAC_RXD3	IO15	
	EMAC_CLK_OUT	IO16	
	EMAC_CLK_OUT_180	IO17	
	EMAC_TX_ER	IO4	
	EMAC_MDC_out	Any GPIO	
	EMAC_MDI_in	Any GPIO	
	EMAC_MDO_out	Any GPIO	
EMAC_CRS_out	Any GPIO		
EMAC_COL_out	Any GPIO		

3.4Electrical Characteristic

3.4.1Maximum Ratings

Table-7. Maximum Ratings

Ratings	Condition	Value	Unit
Storage Temperature	/	-45 to 85	°C
Maximum Soldering Temperature	/	245	°C
Supply Voltage	IPC/JEDEC J-STD-020	+2.7 to +3.6	V

3.4.2 Recommended Operating Environment

Table-8 Recommended Operating Environment

Working Environment	Name	Min Value	Typical Values	Max Value	Unit
Operating Temperature	/	-40	20	85	°C
Supply Voltage	VDD	2.7	3.3	3.6	V

3.4.3 Digital Port Characteristics

Table-9 Digital Port Characteristics

Port	Typical Values	Min Value	Max Value	Unit
Input low logic level	VIL	-0.3	0.25VDD	V
Input high logic level	VIH	0.75vdd	VDD+0.3	V
Output low logic level	VOL	N	0.1VDD	V
Output high logic level	VOL	0.8VDD	N	V

3.5 RF Characteristics

3.5.1 Wi-Fi Radio

Table-10 Wi-Fi Radio Characteristics

Description	Min	Typical	Max	Unit
Input frequency	2412	-	2484	MHz
Input reflection	-	-	-10	dB
Sensitivity				
DSSS, 1 Mbps	-	-98	-	dBm
CCK, 11 Mbps	-	-90	-	dBm
OFDM, 6 Mbps	-	-93	-	dBm
OFDM, 54 Mbps	-	-75	-	dBm
HT20, MCS0	-	-93	-	dBm
HT20, MCS7	-	-73	-	dBm
HT40, MCS0	-	-90	-	dBm
HT40, MCS7	-	-70	-	dBm
MCS32	-	-91	-	dBm
Adjacent channel rejection				
OFDM, 6 Mbps	-	37	-	dB
OFDM, 54 Mbps	-	21	-	dB
HT20, MCS0	-	37	-	dB
HT20, MCS7	-	20	-	dB

3.5.2 BLE Radio
Table-11 Receiver Characteristics — BLE

Parameter	Conditions	Min	Typ	Max	Unit
Sensitivity @30.8% PER	-	-	-98	-	dBm
Maximum received signal @30.8% PER	-	0	-	-	dBm
Co-channel C/I	-	-	10	-	dB
Adjacent channel selectivity C/I	F = F0 + 1 MHz	-	-5	-	dB
	F = F0 - 1 MHz	-	-5	-	dB
	F = F0 + 2 MHz	-	-25	-	dB
	F = F0 - 2 MHz	-	-35	-	dB
	F = F0 + 3 MHz	-	-25	-	dB
	F = F0 - 3 MHz	-	-45	-	dB
Out-of-band blocking performance	30 MHz - 2000 MHz	-10	-	-	dBm
	2000 MHz - 2400 MHz	-27	-	-	dBm
	2500 MHz - 3000 MHz	-27	-	-	dBm
	3000 MHz - 12.5 GHz	-10	-	-	dBm
Intermodulation	-	-36	-	-	dBm

Table-12 Transmitter Characteristics — BLE

Parameter	Conditions	Min	Typ	Max	Unit
RF transmit power	-	-	0	-	dBm
Gain control step	-	-	±3	-	dBm
RF power control range	-	-12	-	+12	dB
Adjacent channel transmit power	F = F0 + 1 MHz	-	-14.6	-	dBm
	F = F0 - 1 MHz	-	-12.7	-	dBm
	F = F0 + 2 MHz	-	-44.3	-	dBm
	F = F0 - 2 MHz	-	-38.7	-	dBm
	F = F0 + 3 MHz	-	-49.2	-	dBm
	F = F0 - 3 MHz	-	-44.7	-	dBm
	F = F0 + > 3 MHz	-	-50	-	dBm
	F = F0 - > 3 MHz	-	-50	-	dBm
Δf1avg	-	-	-	265	kHz
Δf2max	-	247	-	-	kHz
Δf2avg/Δf1avg	-	-	-0.92	-	-
ICFT	-	-	-10	-	kHz
Drift rate	-	-	0.7	-	kHz/50 μs
Drift	-	-	2	-	kHz

4. Mechanical Dimensions

4.1 Module Size

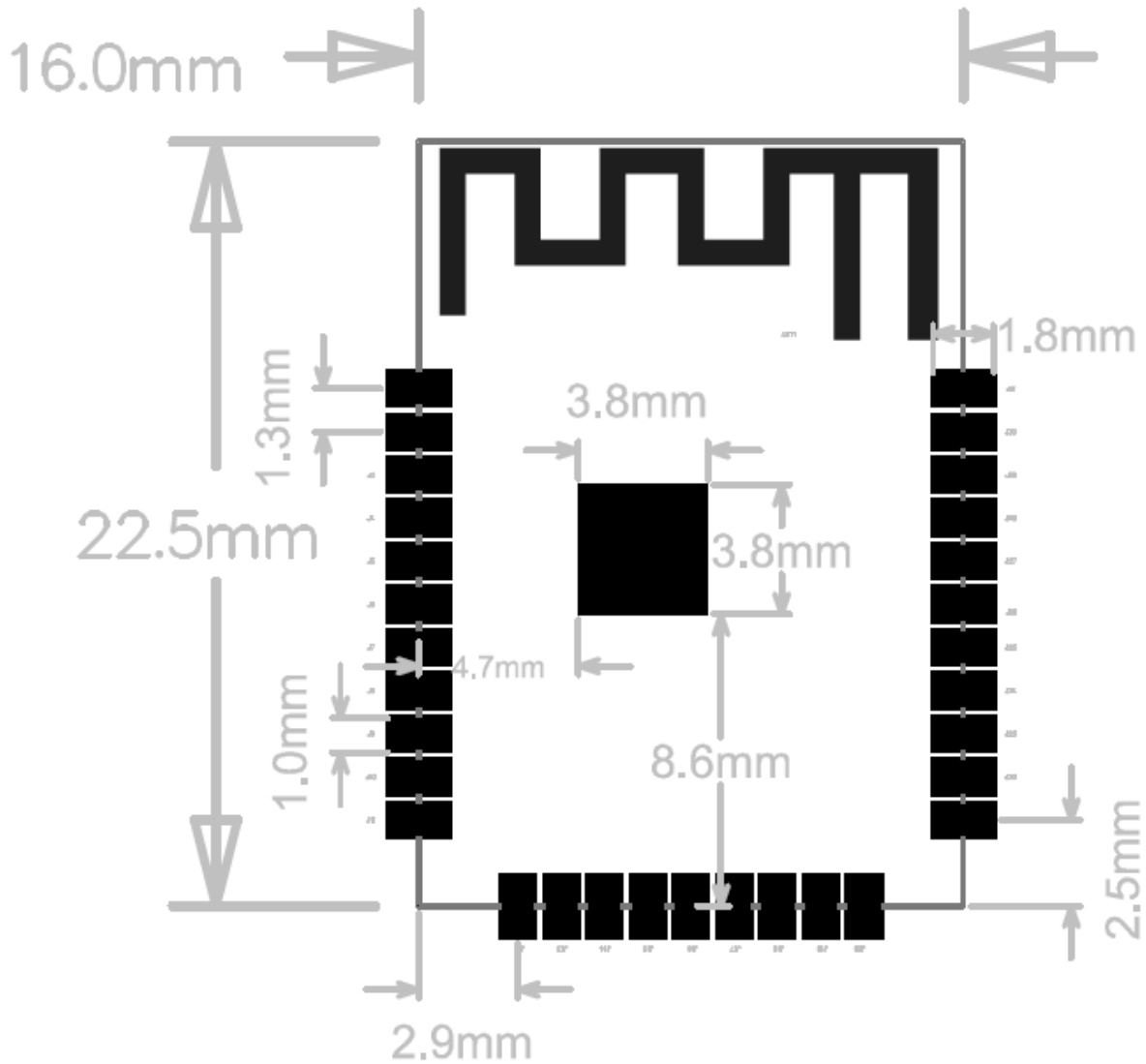

Figure -2 Module Size (Front View+back projection view)

4.2 Schematics

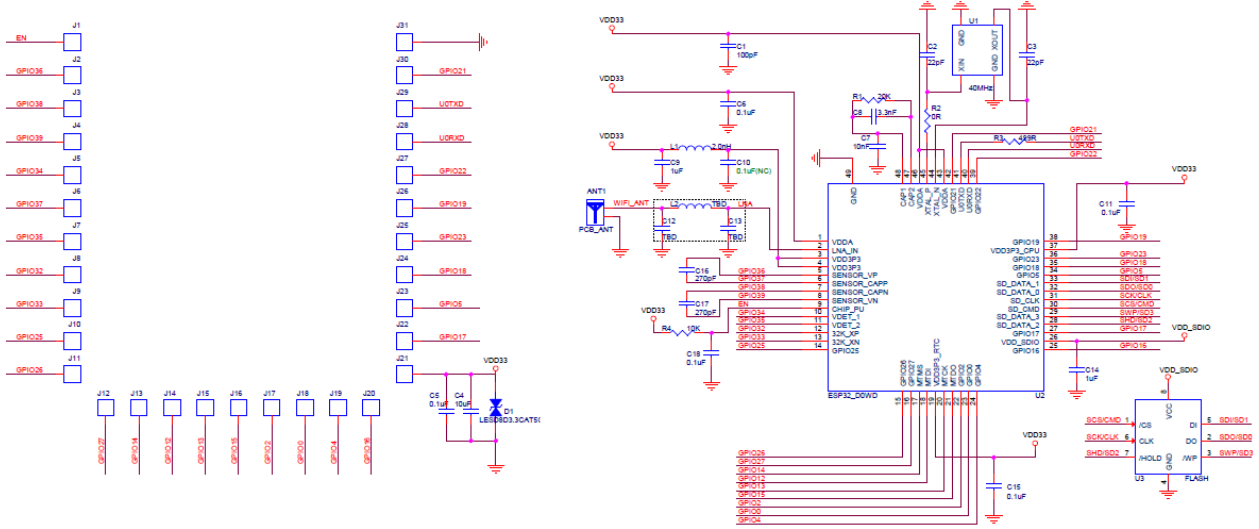

Figure -3 WT32-S1 Schematics

5. Product Trial

- Forum: bbs.wireless-tag.com
- Technical Support : support@wireless-tag.com

