

# RK3588S (Power&Gnd)

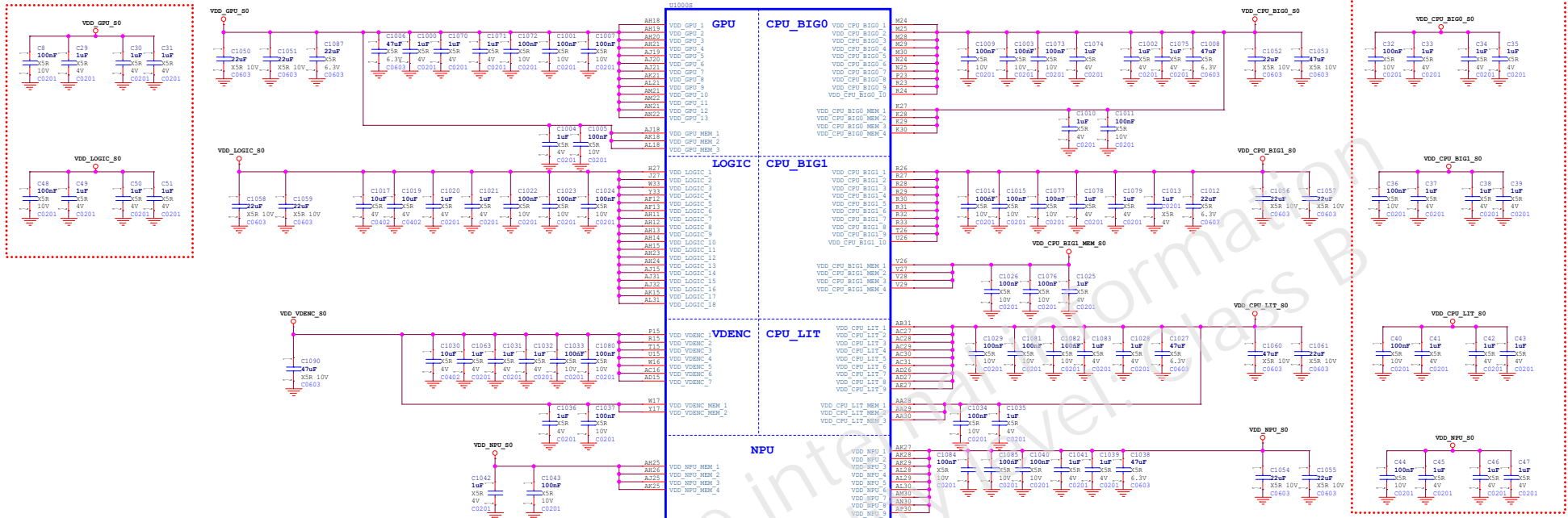

RK3588S  
BGA1253\_17R00X17R00X1R10

Q10000	Q10000	Q10000	Q10000	Q10000	Q10000	Q10000	Q10000	Q10000	Q10000
A1 VSS1	VSS1	A22	VSS101	VSS151	A41	VSS201	VSS251	A60	VSS301
A2 VSS2	VSS2	A23	VSS102	VSS152	A42	VSS202	VSS252	A61	VSS302
A3 VSS3	VSS3	A24	VSS103	VSS153	A43	VSS203	VSS253	A62	VSS303
A4 VSS4	VSS4	A25	VSS104	VSS154	A44	VSS204	VSS254	A63	VSS304
A5 VSS5	VSS5	A26	VSS105	VSS155	A45	VSS205	VSS255	A64	VSS305
A6 VSS6	VSS6	A27	VSS106	VSS156	A46	VSS206	VSS256	A65	VSS306
A7 VSS7	VSS7	A28	VSS107	VSS157	A47	VSS207	VSS257	A66	VSS307
A8 VSS8	VSS8	A29	VSS108	VSS158	A48	VSS208	VSS258	A67	VSS308
A9 VSS9	VSS9	A30	VSS109	VSS159	A49	VSS209	VSS259	A68	VSS309
A10 VSS10	VSS10	A31	VSS110	VSS160	A50	VSS210	VSS260	A69	VSS310
A11 VSS11	VSS11	A32	VSS111	VSS161	A51	VSS211	VSS261	A70	VSS311
A12 VSS12	VSS12	A33	VSS112	VSS162	A52	VSS212	VSS262	A71	VSS312
A13 VSS13	VSS13	A34	VSS113	VSS163	A53	VSS213	VSS263	A72	VSS313
A14 VSS14	VSS14	A35	VSS114	VSS164	A54	VSS214	VSS264	A73	VSS314
A15 VSS15	VSS15	A36	VSS115	VSS165	A55	VSS215	VSS265	A74	VSS315
A16 VSS16	VSS16	A37	VSS116	VSS166	A56	VSS216	VSS266	A75	VSS316
A17 VSS17	VSS17	A38	VSS117	VSS167	A57	VSS217	VSS267	A76	VSS317
A18 VSS18	VSS18	A39	VSS118	VSS168	A58	VSS218	VSS268	A77	VSS318
A19 VSS19	VSS19	A40	VSS119	VSS169	A59	VSS219	VSS269	A78	VSS319
A20 VSS20	VSS20	A41	VSS120	VSS170	A60	VSS220	VSS270	A79	VSS320
A21 VSS21	VSS21	A42	VSS121	VSS171	A61	VSS221	VSS271	A80	VSS321
A22 VSS22	VSS22	A43	VSS122	VSS172	A62	VSS222	VSS272	A81	VSS322
A23 VSS23	VSS23	A44	VSS123	VSS173	A63	VSS223	VSS273	A82	VSS323
A24 VSS24	VSS24	A45	VSS124	VSS174	A64	VSS224	VSS274	A83	VSS324
A25 VSS25	VSS25	A46	VSS125	VSS175	A65	VSS225	VSS275	A84	VSS325
A26 VSS26	VSS26	A47	VSS126	VSS176	A66	VSS226	VSS276	A85	VSS326
A27 VSS27	VSS27	A48	VSS127	VSS177	A67	VSS227	VSS277	A86	VSS327
A28 VSS28	VSS28	A49	VSS128	VSS178	A68	VSS228	VSS278	A87	VSS328
A29 VSS29	VSS29	A50	VSS129	VSS179	A69	VSS229	VSS279	A88	VSS329
A30 VSS30	VSS30	A51	VSS130	VSS180	A70	VSS230	VSS280	A89	VSS330
A31 VSS31	VSS31	A52	VSS131	VSS181	A71	VSS231	VSS281	A90	VSS331
A32 VSS32	VSS32	A53	VSS132	VSS182	A72	VSS232	VSS282	A91	VSS332
A33 VSS33	VSS33	A54	VSS133	VSS183	A73	VSS233	VSS283	A92	VSS333
A34 VSS34	VSS34	A55	VSS134	VSS184	A74	VSS234	VSS284	A93	VSS334
A35 VSS35	VSS35	A56	VSS135	VSS185	A75	VSS235	VSS285	A94	VSS335
A36 VSS36	VSS36	A57	VSS136	VSS186	A76	VSS236	VSS286	A95	VSS336
A37 VSS37	VSS37	A58	VSS137	VSS187	A77	VSS237	VSS287	A96	VSS337
A38 VSS38	VSS38	A59	VSS138	VSS188	A78	VSS238	VSS288	A97	VSS338
A39 VSS39	VSS39	A60	VSS139	VSS189	A79	VSS239	VSS289	A98	VSS339
A40 VSS40	VSS40	A61	VSS140	VSS190	A80	VSS240	VSS290	A99	VSS340
A41 VSS41	VSS41	A62	VSS141	VSS191	A81	VSS241	VSS291	A100	VSS341
A42 VSS42	VSS42	A63	VSS142	VSS192	A82	VSS242	VSS292	A101	VSS342
A43 VSS43	VSS43	A64	VSS143	VSS193	A83	VSS243	VSS293	A102	VSS343
A44 VSS44	VSS44	A65	VSS144	VSS194	A84	VSS244	VSS294	A103	VSS344
A45 VSS45	VSS45	A66	VSS145	VSS195	A85	VSS245	VSS295	A104	VSS345
A46 VSS46	VSS46	A67	VSS146	VSS196	A86	VSS246	VSS296	A105	VSS346
A47 VSS47	VSS47	A68	VSS147	VSS197	A87	VSS247	VSS297	A106	VSS347
A48 VSS48	VSS48	A69	VSS148	VSS198	A88	VSS248	VSS298	A107	VSS348
A49 VSS49	VSS49	A70	VSS149	VSS199	A89	VSS249	VSS299	A108	VSS349
A50 VSS50	VSS50	A71	VSS150	VSS200	A90	VSS250	VSS300	A109	VSS350



# RK3588S (DDR PHY)

U1000A RK3588S



U1000B RK3588S

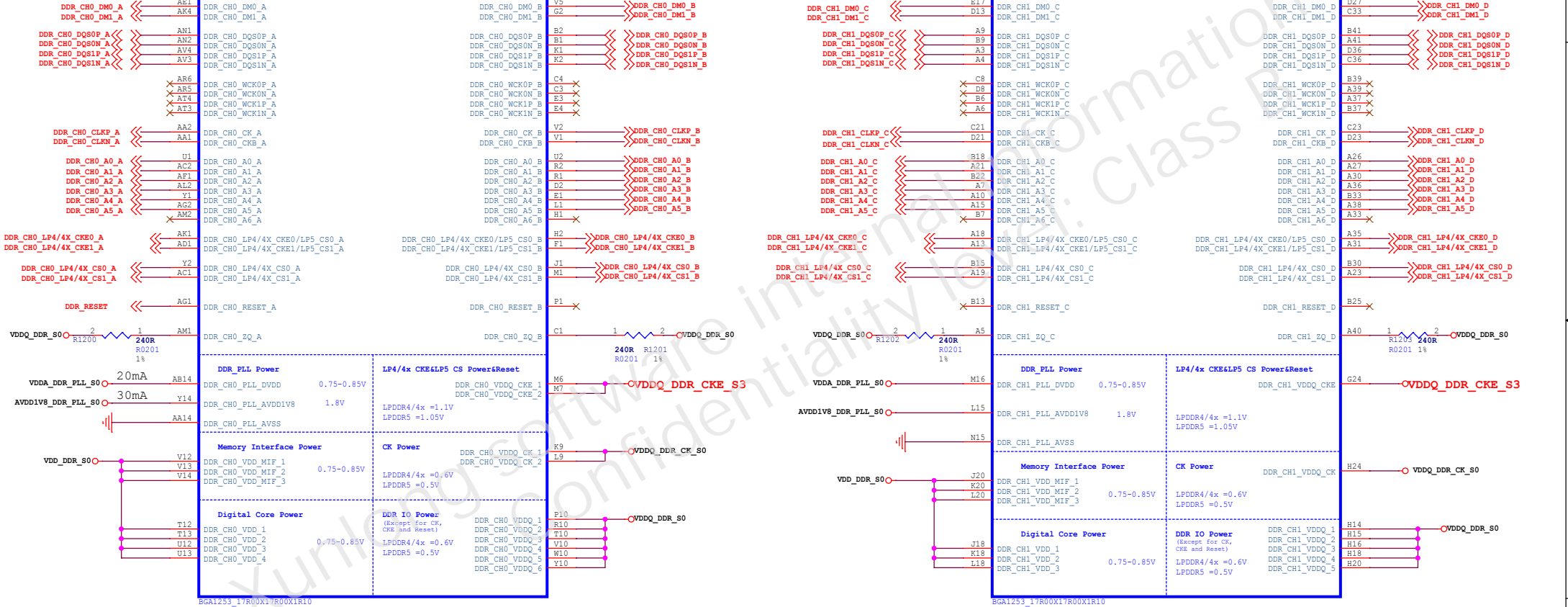

## DDR FILTER

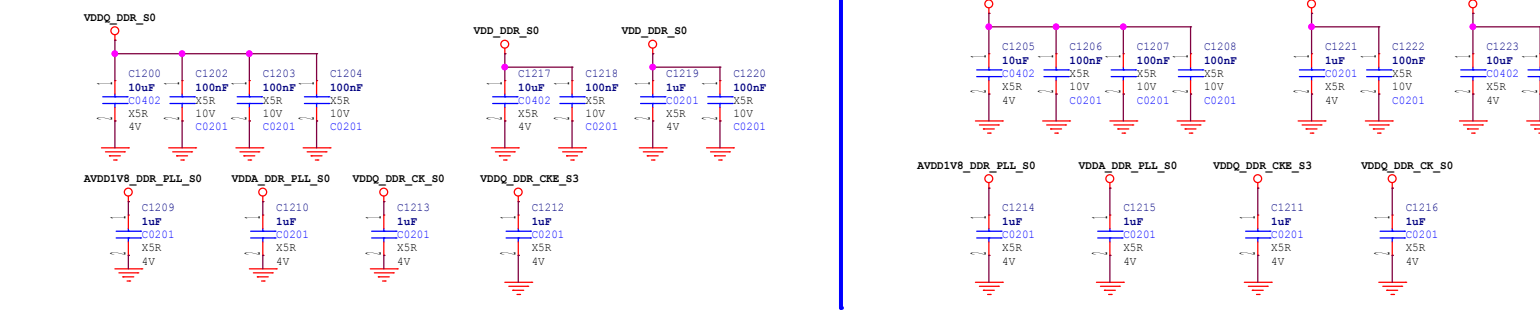

**Kunlong Co., Limited**

Design Name: **ORANGEPI 5**

Size: A3, Page Name: **RK3588S DDR Controller**, Rev: 1.2

Date: Tuesday, November 08, 2022, Sheet: 12 of 36

# RK3588S (EMMCIO Domain)

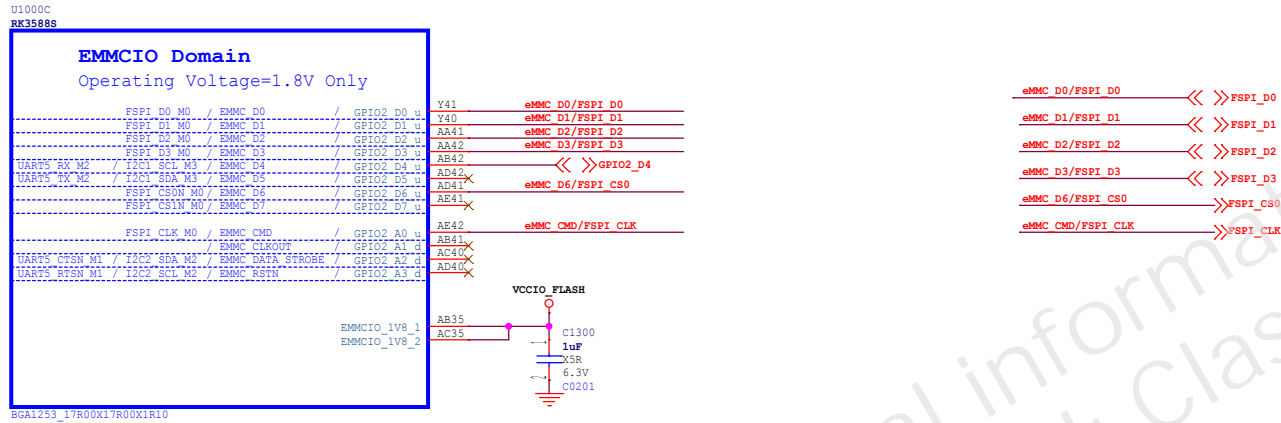

# RK3588S (VCCIO2 Domain)

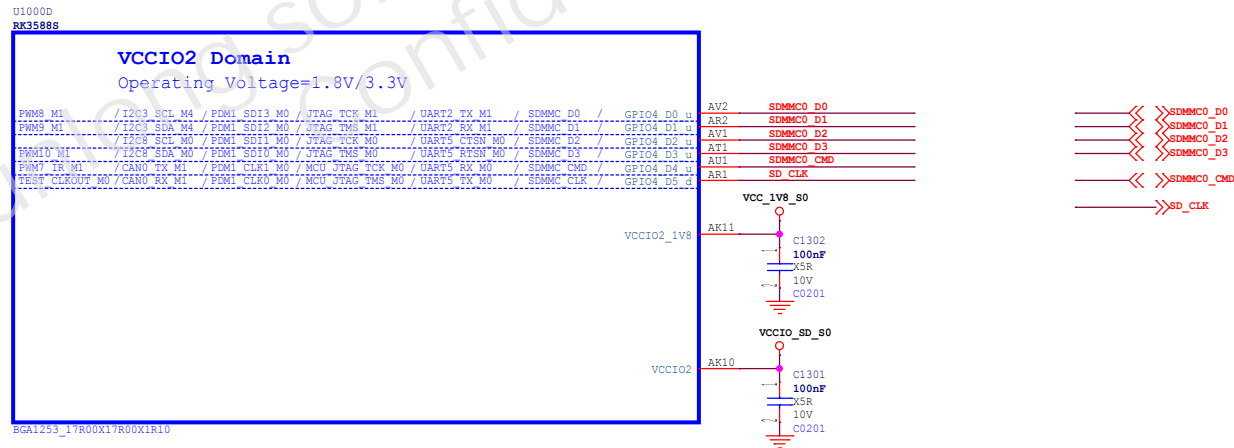

# RK3588S (USB3.0/DP1.4)

U1000L RK3588S

## USB 3.0 OTG of TYPECO /DP1.4 ALT

USB:U3/Gen1  
DP:RBR/HBR/HBR2/HBR3

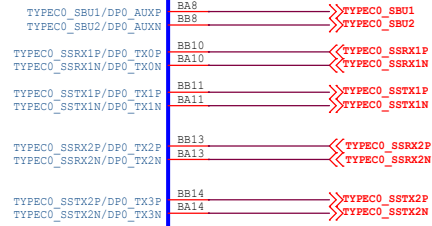

## POWER

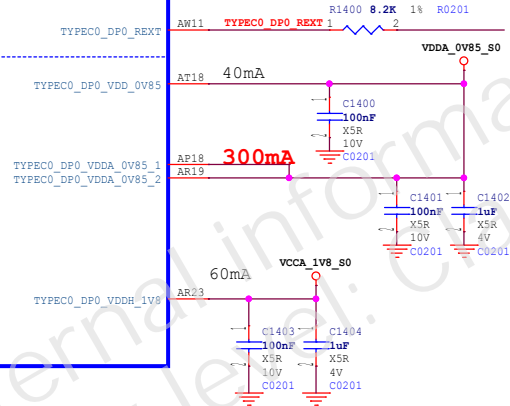

BGA1253\_17R00X17R00X1R10

# RK3588S (USB2.0)

U1000K RK3588S

## USB2.0 OTG of TYPECO

HS/FS/LS  
Download Port

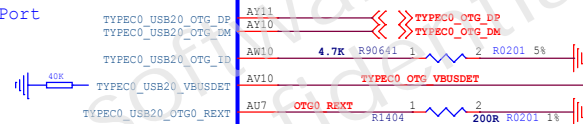

## USB2.0 HOST0

HS/FS/LS



## USB2.0 HOST1

HS/FS/LS

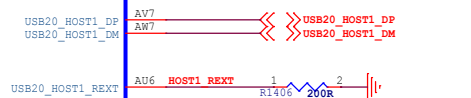

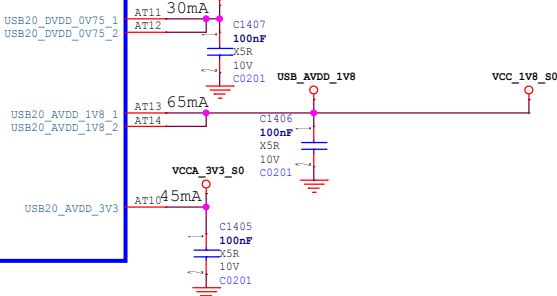

## USB2.0 POWER

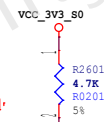

BGA1253\_17R00X17R00X1R10

## USB Detection



	<b>Xunlong Co., Limited</b>		
	Design Name	ORANGEPI 5	
Size	Page Name	RK3588S_USB20/USB30/DP PHY	Rev
A3			1.2
Date:	Tuesday, November 08, 2022	Sheet	14 of 36

# RK3588S (SARADC/OTP/TSADC)

- SARADC\_VIN2\_LCD\_ID
- SARADC\_VIN4\_LCD\_ID
- SARADC\_VIN3\_HP\_HOOK

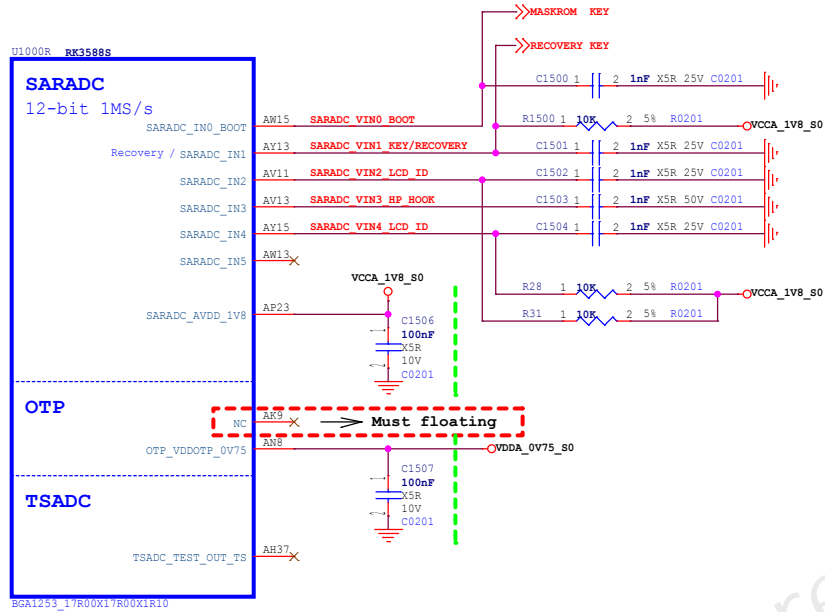

## BOOT MODE CONFIG

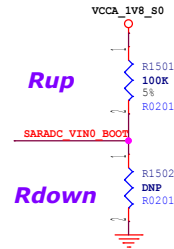

Item	Rup	Rdown	ADC	BOOT MODE(saradc_in5)
LEVEL1	DNP	100K	0	USB (Maskrom mode)
LEVEL2	100K	20K	682	SD Card-USB
LEVEL3	100K	51K	1365	EMMC-USB
LEVEL4	100K	100K	2047	FSPI M0-USB
LEVEL5	100K	200K	2730	FSPI M1-USB
LEVEL6	100K	499K	3412	FSPI M2-USB
LEVEL7	100K	DNP	4095	FSPI M2-FSPI M0-EMMC -SD Card-USB

# RK3588S (VCCIO1 Domain)

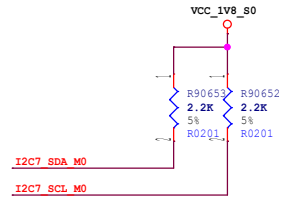
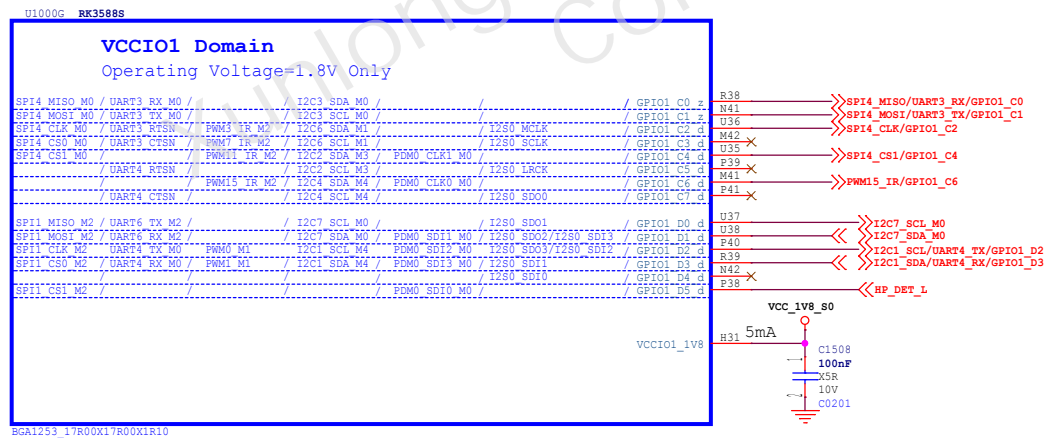

**Xunlong Co., Limited**

Design Name: **ORANGEPI 5**

Size: A3 Page Name: **RK3588S\_SARADC/1.8V GPIO** Rev: 1.2

Date: Tuesday, November 08, 2022 Sheet: 15 of 36



# RK3588S (MIPI\_CSI)

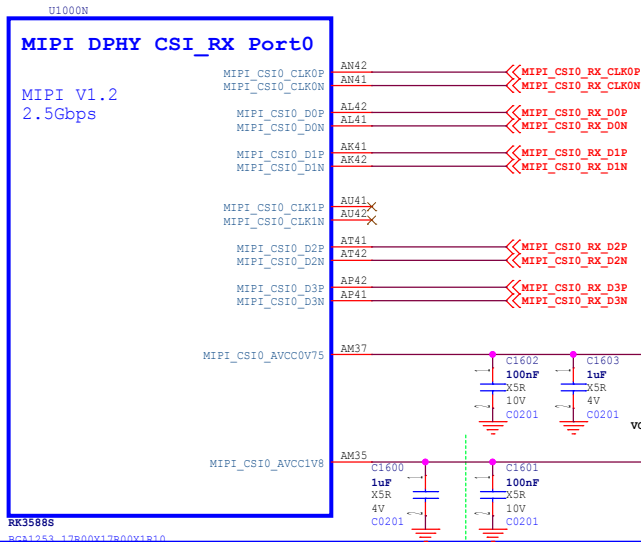

MIPI CSI\_RX:  
100 Ohm ±10%

Option1	Sensor1 x4Lane	MIPI_CSI_RX_D0-3 MIPI_CSI_RX_CLKO
Option2	Sensor1 x2Lane + Sensor2 x2Lane	MIPI_CSI_RX_D0-1 MIPI_CSI_RX_CLKO  MIPI_CSI_RX_D2-3 MIPI_CSI_RX_CLKI

# RK3588S (MIPI\_D/C PHY)

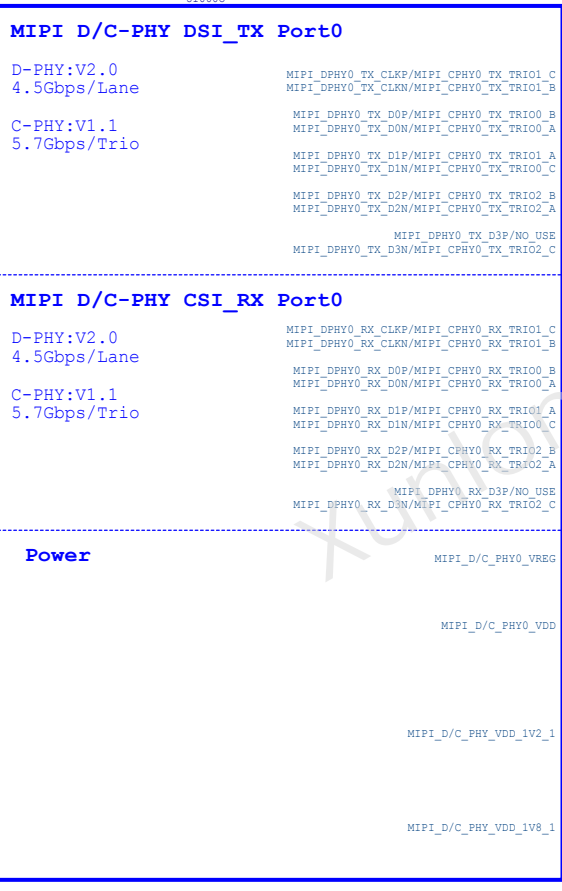

MIPI DPHY:  
100 Ohm ±10%

MIPI CPHY:  
50 Ohm ±10%

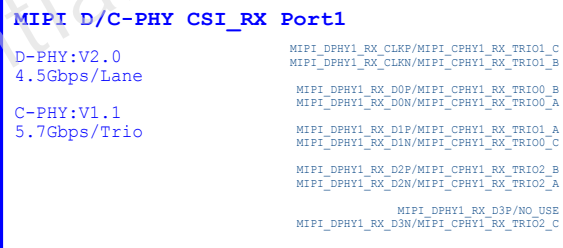
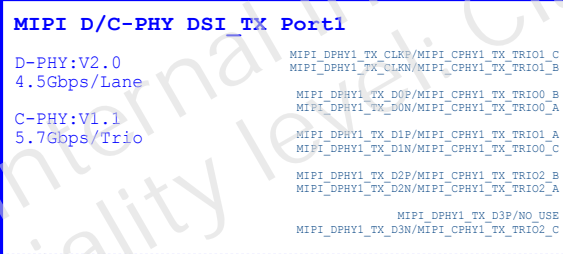

Power

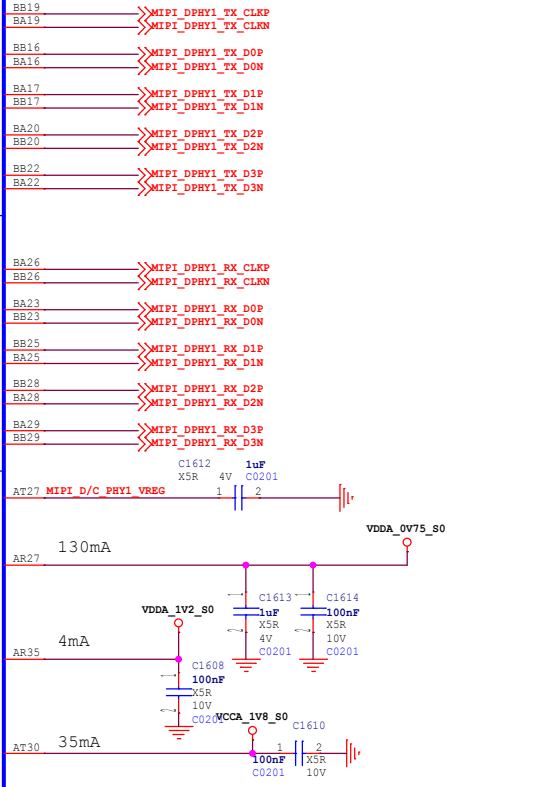

# RK3588S (HDMI2.1 TX/eDP1.3 TX)

**Note:**

The HDMI2.1 trace length is less than 100mm.  
The HDMI2.1 differential trace impedance is 100 OHM.

**HDMI TX**  
100 Ohm ±10%

**eDP TX**  
100 Ohm ±10%

**HDMI TX**  
100 Ohm ±10%

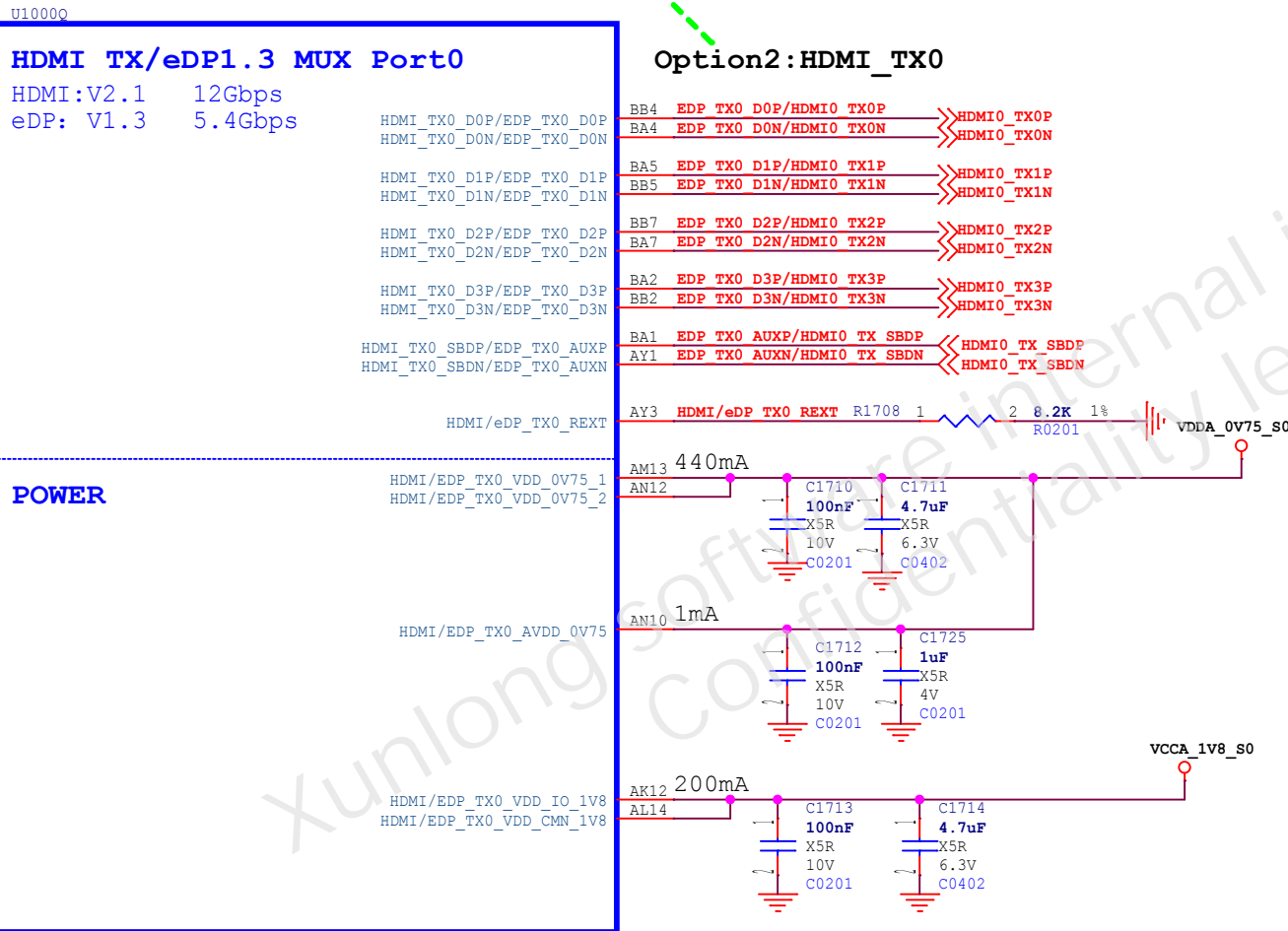

RK3588S  
BGA1253\_17R00X17R00X1R10

Xunlong Confidential Internal information level: Class B

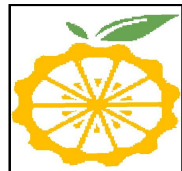

<b>Xunlong Co., Limited</b>			
Design Name			
<b>ORANGEPI 5</b>			
Size A4	Page Name		Rev 1.2
		<b>RK3588S_HDMI/eDP Interface</b>	
Date:	Tuesday, November 08, 2022	Sheet	17 of 36



# RK3588S (PCIE20/SATA30/USB30)

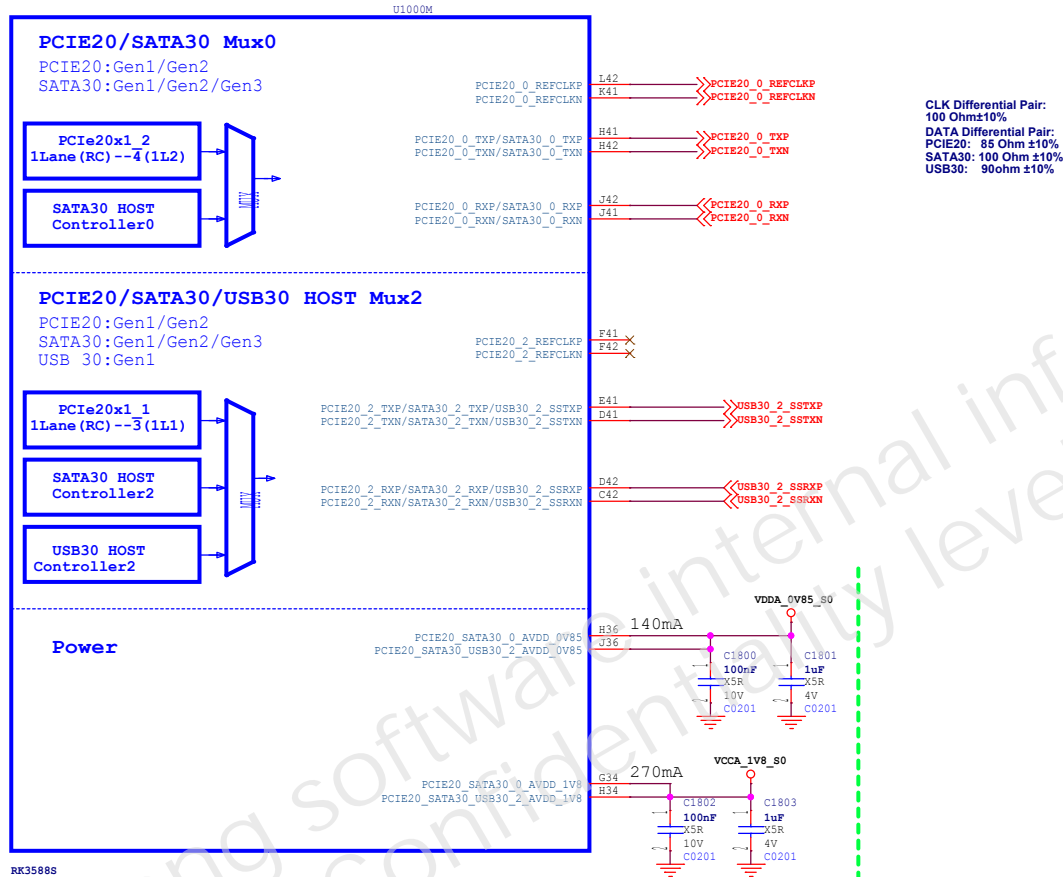

CLK Differential Pair:  
100 Ohm±10%  
DATA Differential Pair:  
PCIE20: 85 Ohm±10%  
SATA30: 100 Ohm±10%  
USB30: 90ohm±10%

RK3588S  
BG1253\_17R00X17R00X1R10

## PCIE2.0 PHY

Controller Name	Data & Clk Lane Configure		Control GPIO
	CLK LANE	DATA LANE	
PCIE20X1_1 RC	PCIE20_2_REFCLKP PCIE20_2_REFCLKN	PCIE20_2_TX PCIE20_2_RX	PCIE20X1_1_CLKREQ_M* PCIE20X1_1_WAKEN_M* PCIE20X1_1_PERSTN_M* PCIE20X1_1_BUTTON_RSTN
PCIE20X1_2 RC	PCIE20_0_REFCLKP PCIE20_0_REFCLKN	PCIE20_0_TX PCIE20_0_RX	PCIE20X1_2_CLKREQ_M* PCIE20X1_2_WAKEN_M* PCIE20X1_2_PERSTN_M* PCIE20X1_2_BUTTON_RSTN

 <b>Xunlong Co., Limited</b>			
Design Name		<b>ORANGEPI 5</b>	
Size A3	Page Name	RK3588S PCIE2/SATA3/USB3 PHY	
Date:	Tuesday, November 08, 2022	Sheet	18 of 36
Rev	1.2		



# USB Type-C Port

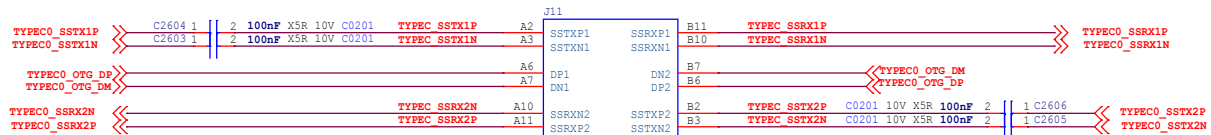
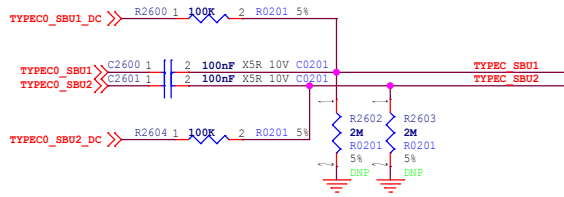

# USB Type-C CC CTRL

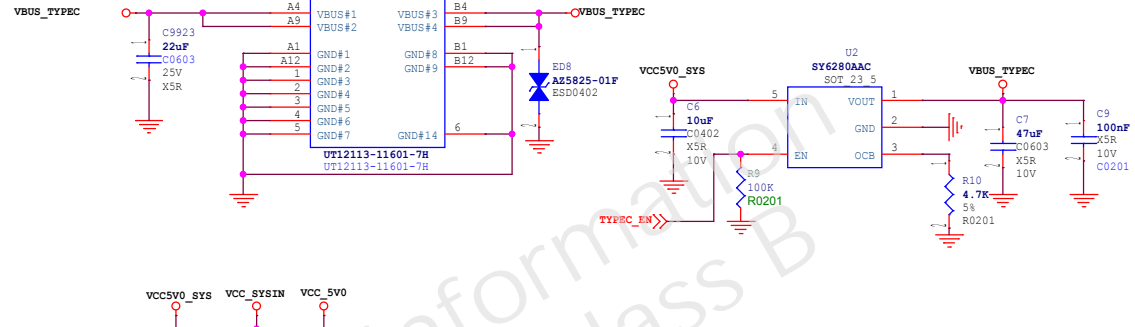
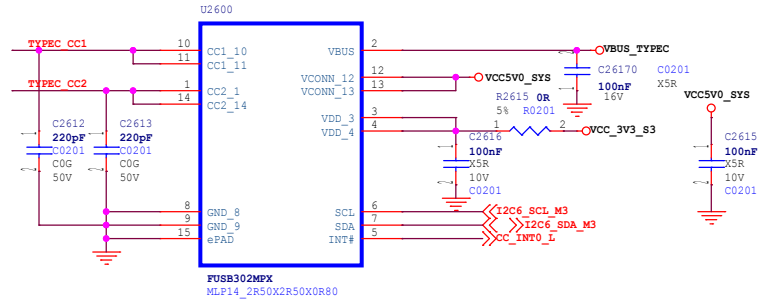

# DCIN-5V/4A

# TYPE-C POWER IN

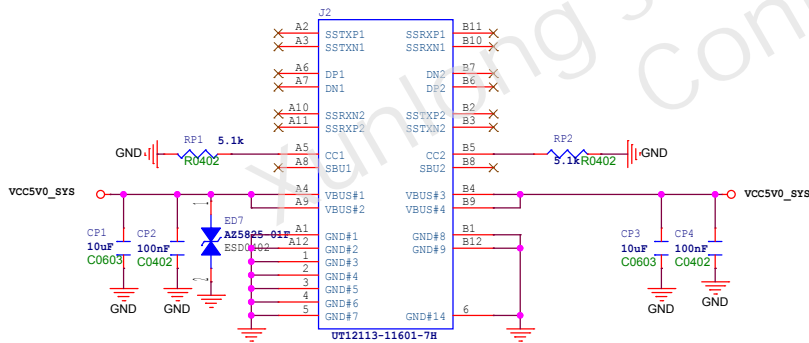

# RTC IC

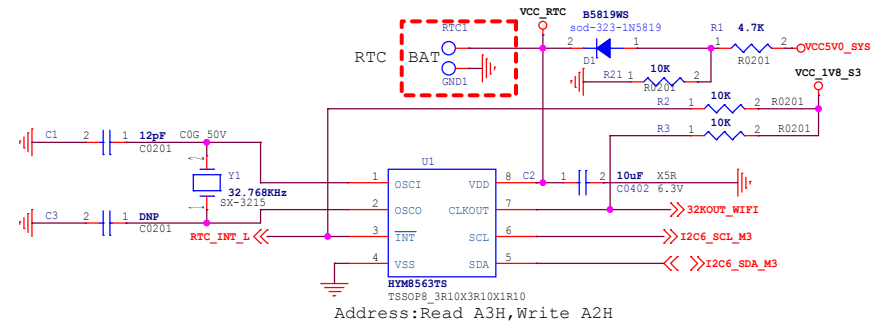

# PMIC1 RK806-1

>>> SLEEP1\_RESET1\_DEVOFF1\_VSEL1  
 >>> VSEL4  
 >>> VSEL5  
 <<< PMIC\_INT\_L  
 <<< PMIC\_RESET\_L

>>> PMIC\_SPI\_CLK  
 >>> PMIC\_SPI\_CS  
 >>> PMIC\_SPI\_MOSI

**IF TVS UNMOUNTED, ESD OR SURGE SHOULD BE DAMAGE THE PMIC!!!**

This device must be mounted. Replacing TVS mode is not recommended, if must, please choose the same specifications  
 Operating Supply Voltage = 5.5V(5.25-6V)  
 Peak Pulse Current >10A (1µs/200µs)  
 Surge Clamping Voltage <6.5V

**DO NOT DELETE IT!**

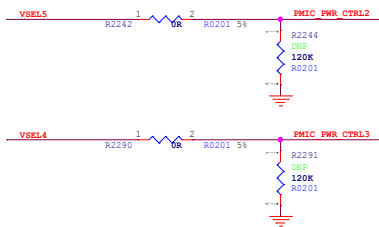

# PMIC RK806-1 BUCK

## 峰值电流 2.5 A

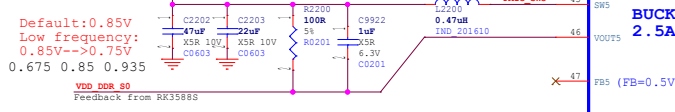

## 峰值电流 1.0 A

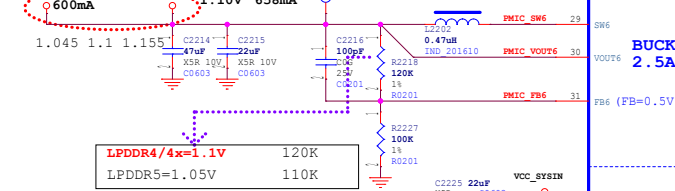

## 峰值电流 232.60mA

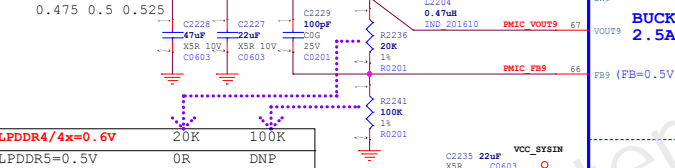

## 峰值电流 2.5 A

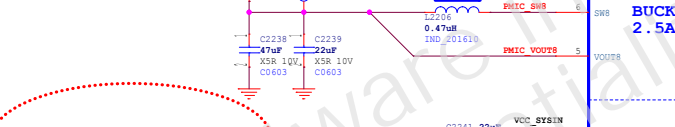

## 峰值电流 1 A

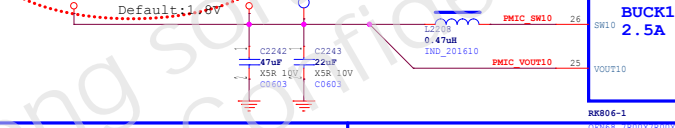

## 峰值电流 6 A

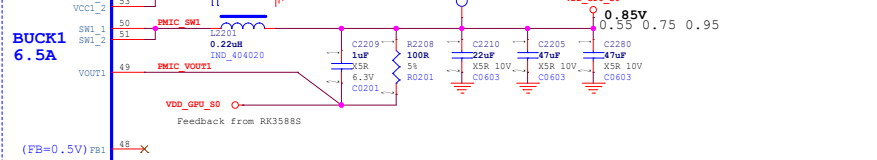

## 峰值电流 3 A

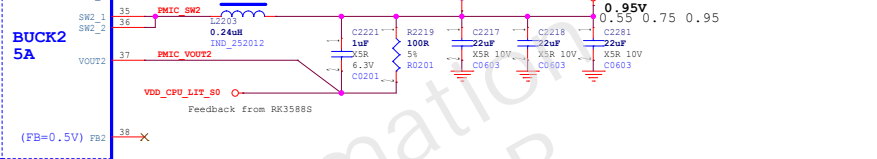

## 峰值电流 2 A

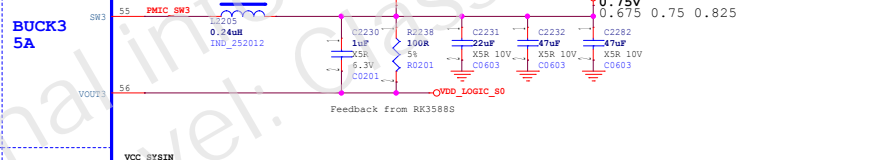

## 峰值电流 2 A

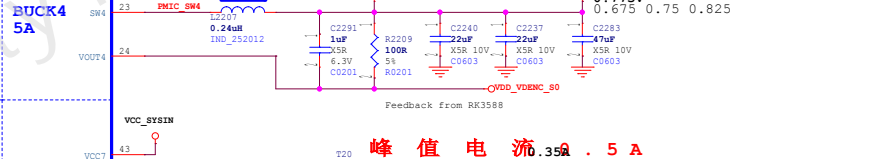

## 峰值电流 35A .5 A

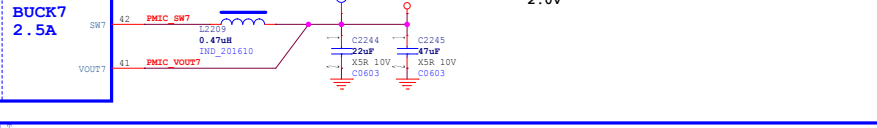

# PMIC RK806-1 Management

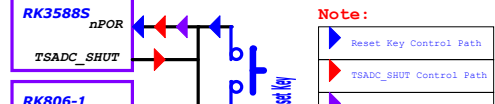
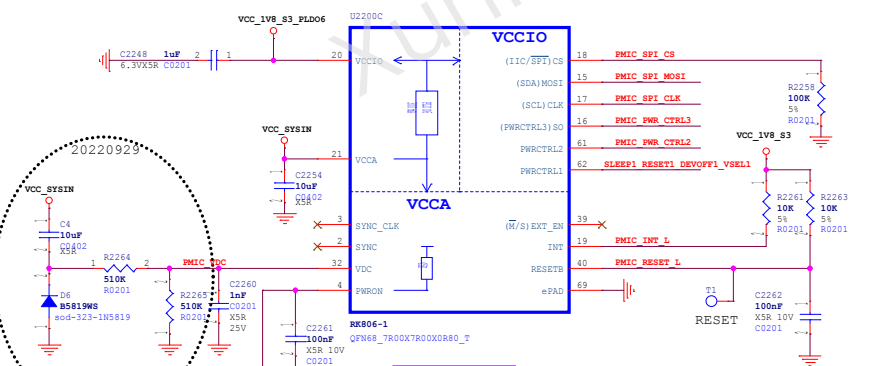

# PMIC RK806-1 LDO

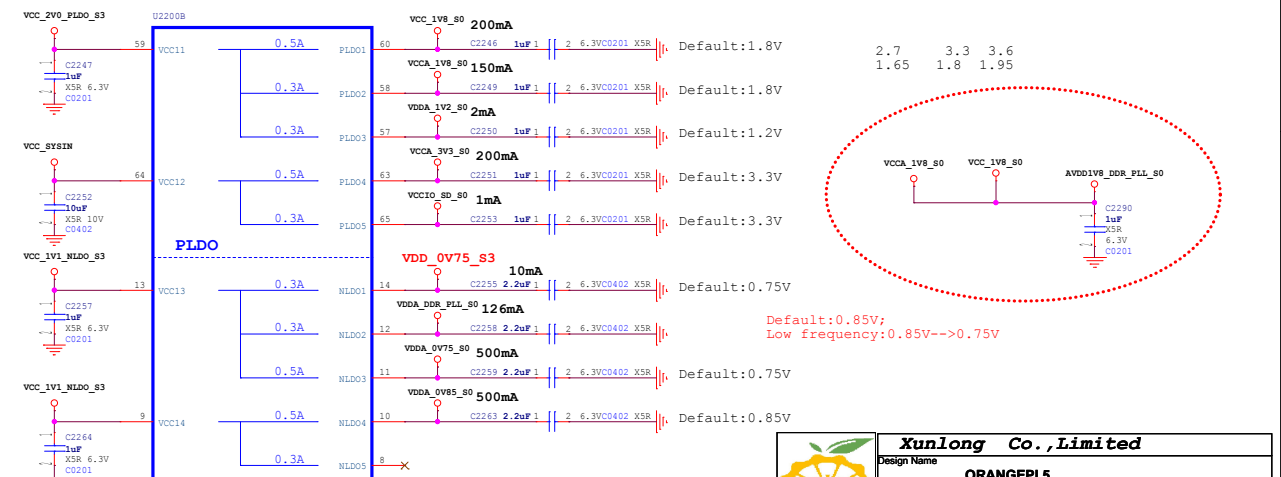

# VDD\_CPU\_BIG0

峰值电流 3.5 A

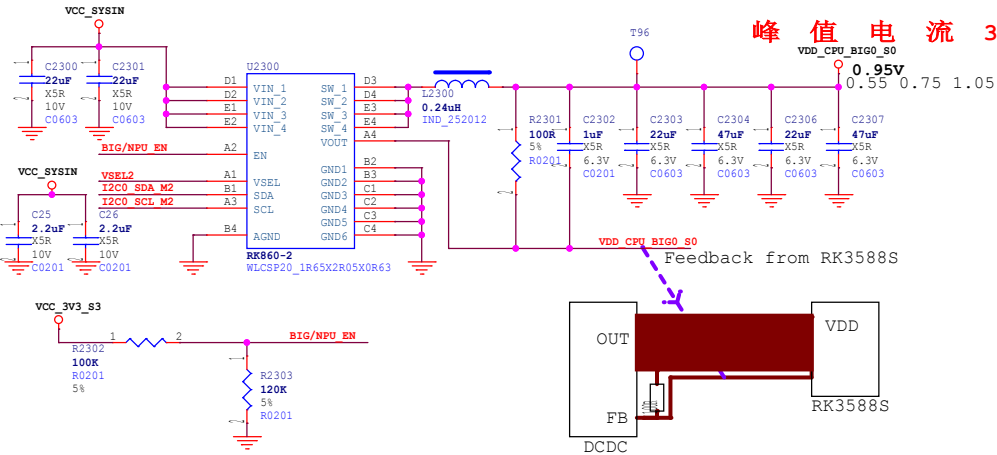

# VDD\_CPU\_BIG1

峰值电流 3.5 A

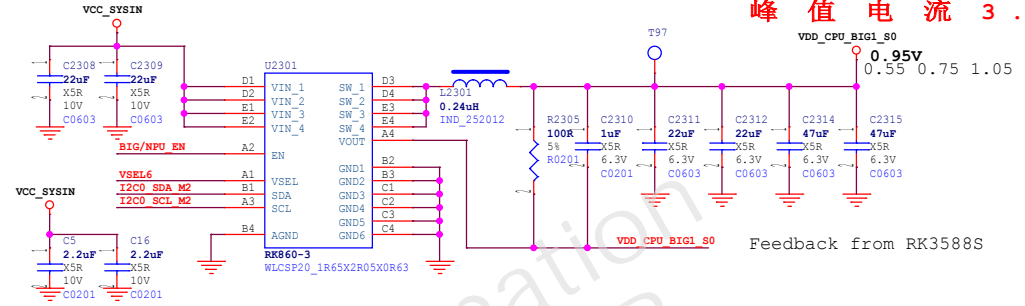

# VDD\_NPU

峰值电流 4 A

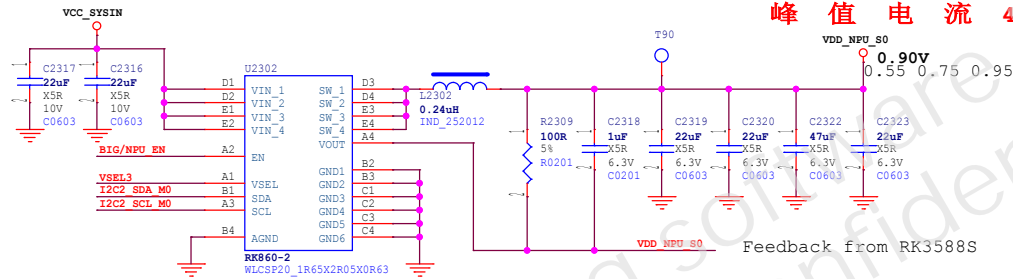

			
<b>Xunlong Co., Limited</b>			
Design Name		<b>ORANGEPI 5</b>	
Size	Page Name		Rev
A3	Power_Ext Discrete		1.2
Date:	Tuesday, November 08, 2022	Sheet	22 of 36

# USB2.0 Type-A Port

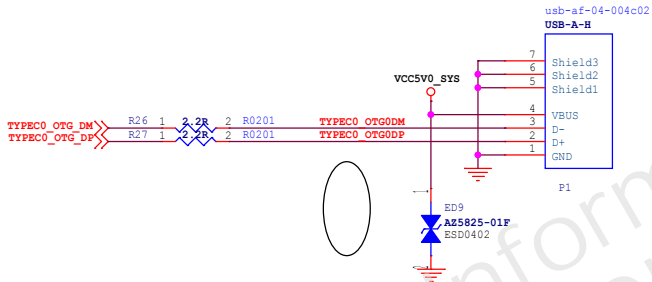

# USB3.0 HOST

- USB20\_HOST0\_DP
- USB20\_HOST0\_DM
- USB20\_HOST1\_DP
- USB20\_HOST1\_DM
- USB30\_2\_SSTXP
- USB30\_2\_SSTXN
- USB30\_2\_SSRXP
- USB30\_2\_SSRXN

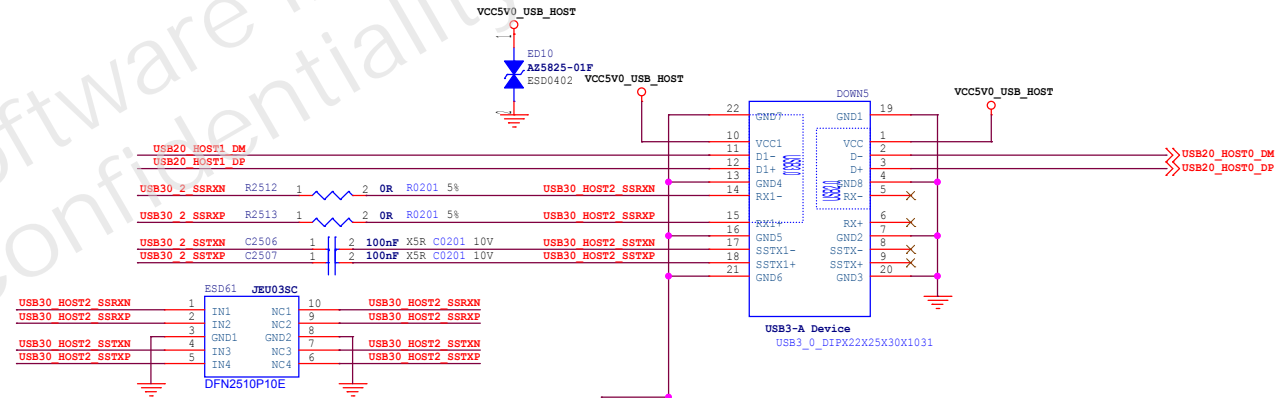
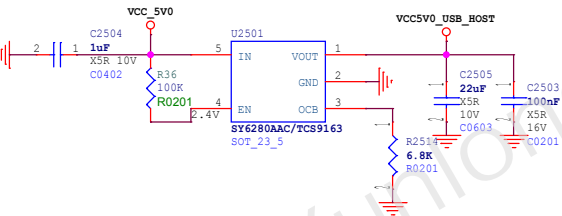

Cj <= 0.3pF

# LPDDR4/4X

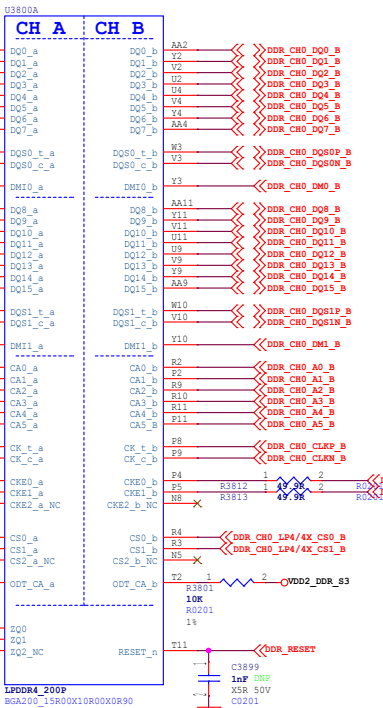

LPDDR4 200P  
BGA200\_15R00X10R00X090

VCC18\_PMU\_DDR\_S3 U3800A

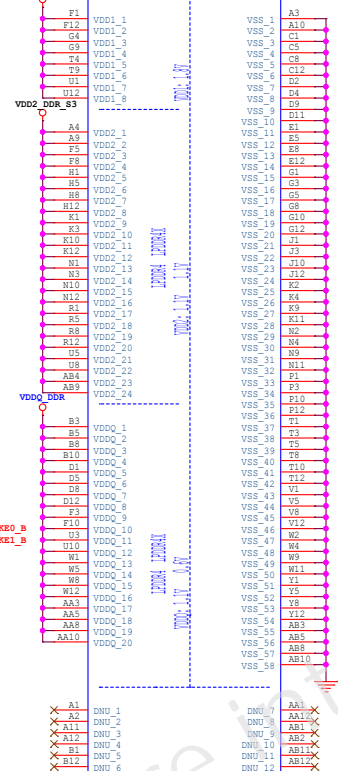

H9HCNNPCMLXR-NEE 200FBGA LPDDR4X 4266Mbps 4GB

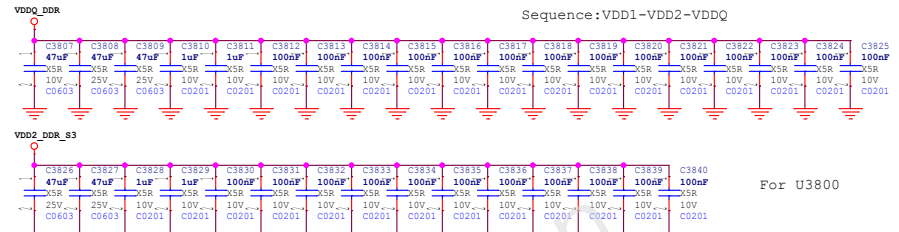

For U3800

VCC18\_PMU\_DDR\_S3

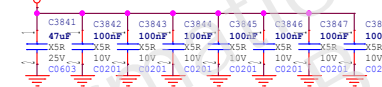

LPDDR4 LPDDR4X  
VDD1: 1.70-1.95 1.70-1.95  
VDD2: 1.06-1.17 1.06-1.17  
VDDQ: 1.06-1.17 0.57-0.65

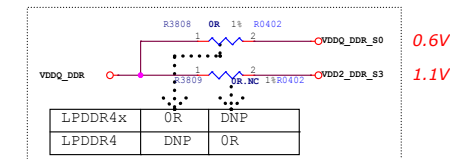

0.6V  
1.1V

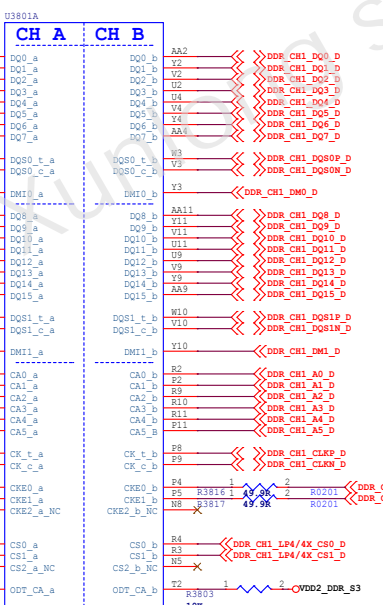

LPDDR4 200P  
BGA200\_15R00X10R00X090

VCC18\_PMU\_DDR\_S3 U3801B

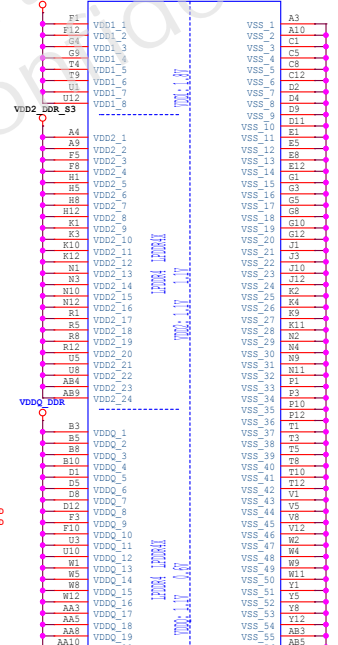

H9HCNNPCMLXR-NEE 200FBGA LPDDR4X 4266Mbps 4GB

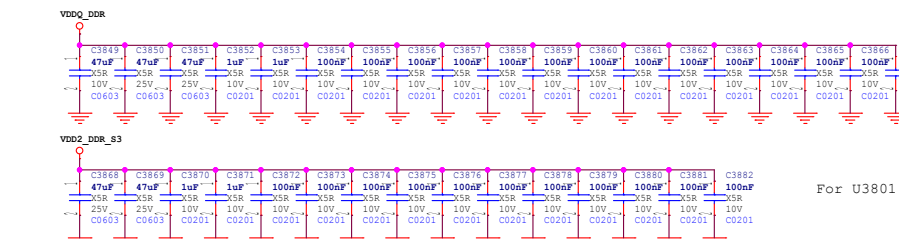

For U3801

VCC18\_PMU\_DDR\_S3

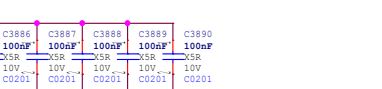



# TF CARD

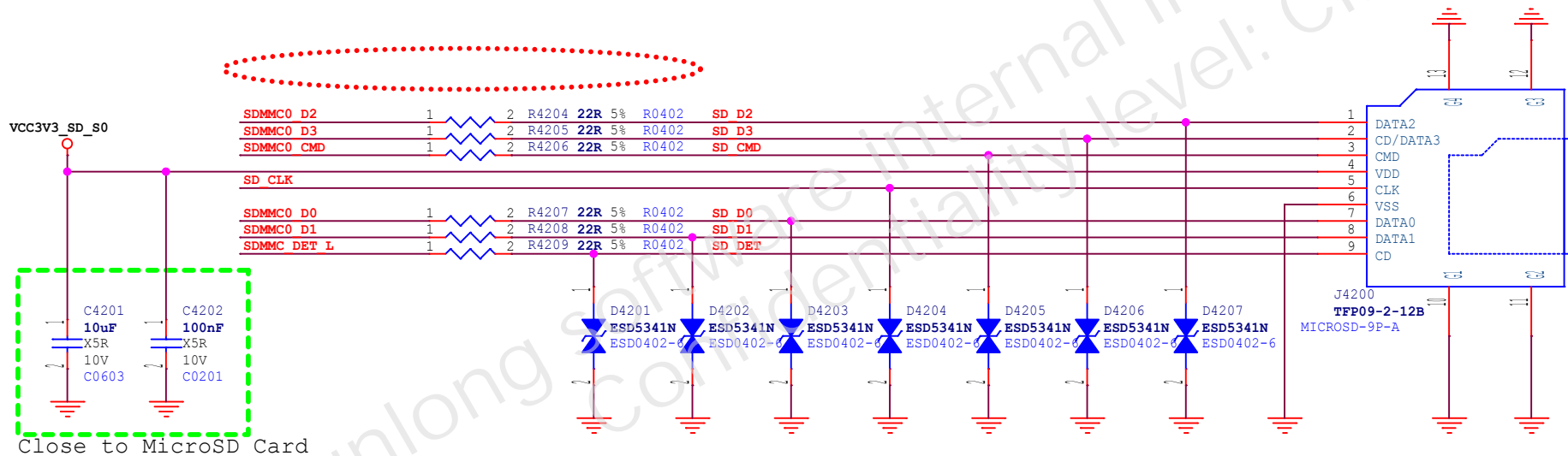
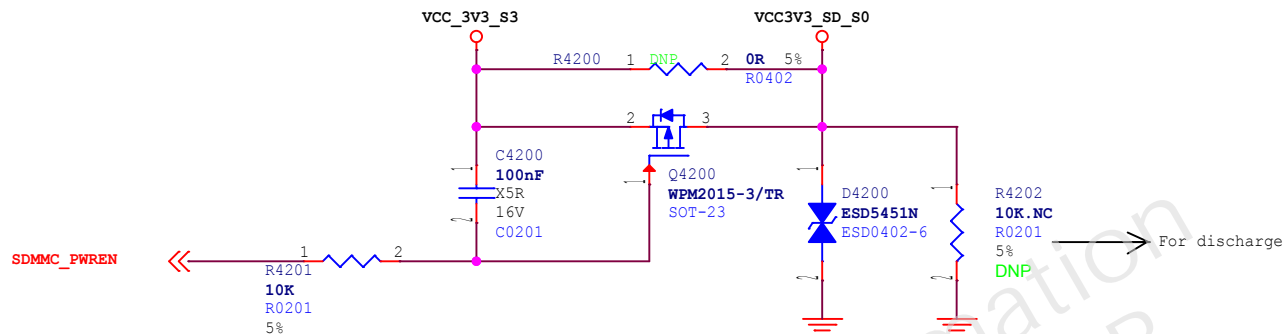
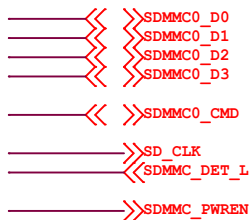

Close to MicroSD Card

MicroSD Card

**Rockchip Confidential**



<b>Xunlong Co., Limited</b>			
Design Name			
<b>ORANGEPI 5</b>			
Size A4	Page Name <b>Flash-TF Card</b>		Rev 1.2
Date:	Tuesday, November 08, 2022	Sheet	26 of 36

# MIPI-CSIO\_RX

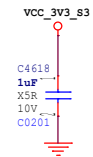
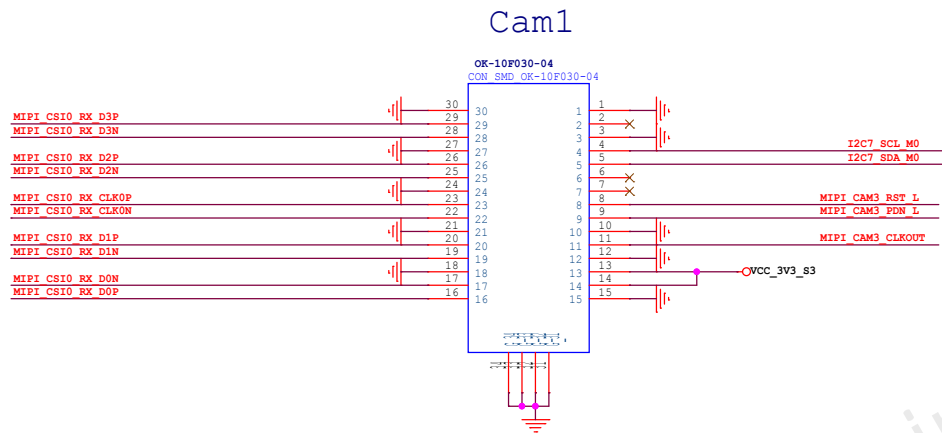
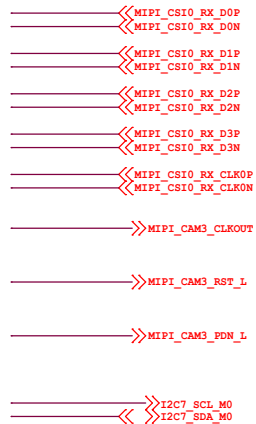

Xunlong software internal information  
 Confidentiality level: Class B



<b>Xunlong Co., Limited</b>			
Design Name			
<b>ORANGEPI 5</b>			
Size	Page Name	Rev	
A3	VI-Camera MIPI CSIO-RX / Debug	1.2	
Date:	Tuesday, November 08, 2022	Sheet	27 of 36

# VI-Camera DPHY\_RX

## MIPI D-PHY0 Cam2

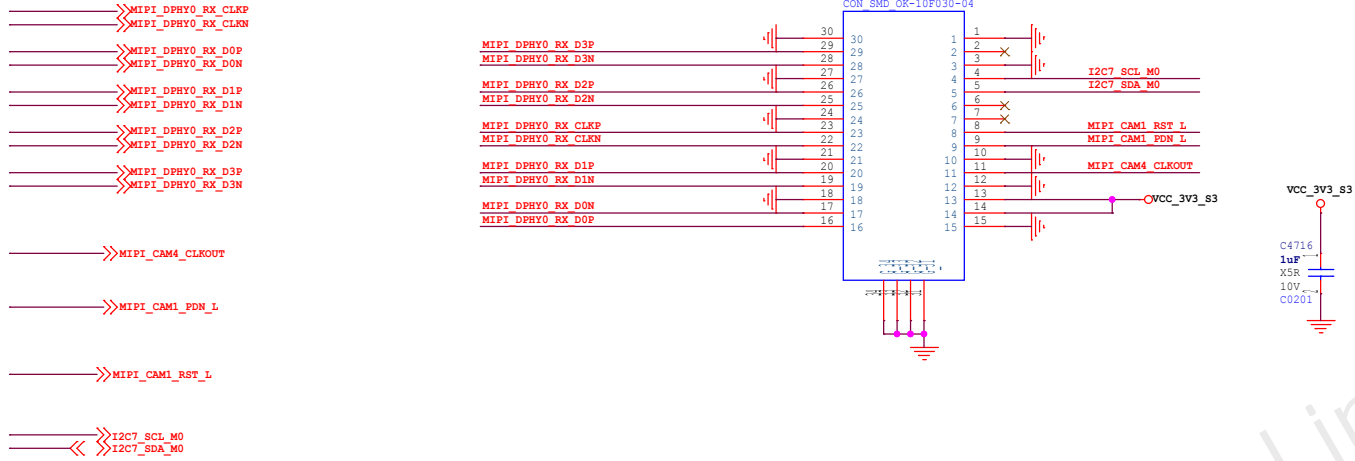

# VI-Camera DPHY\_RX

## MIPI D-PHY1 Cam3

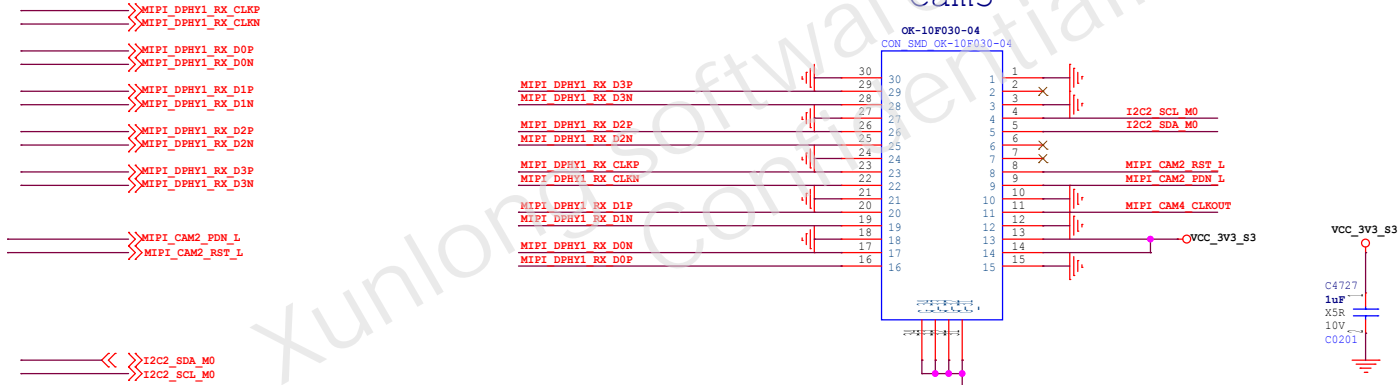

# HDMI2.1 TX0

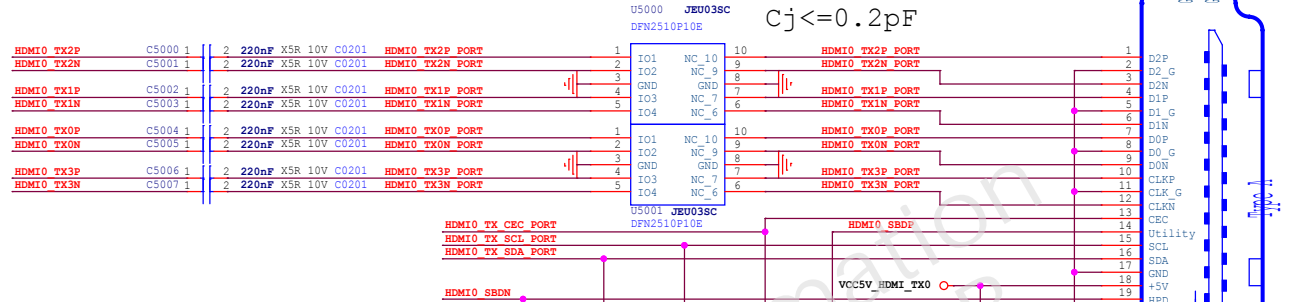
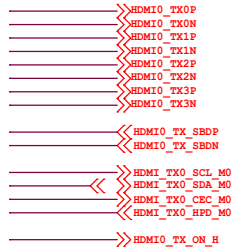

## HDMI TX DDC

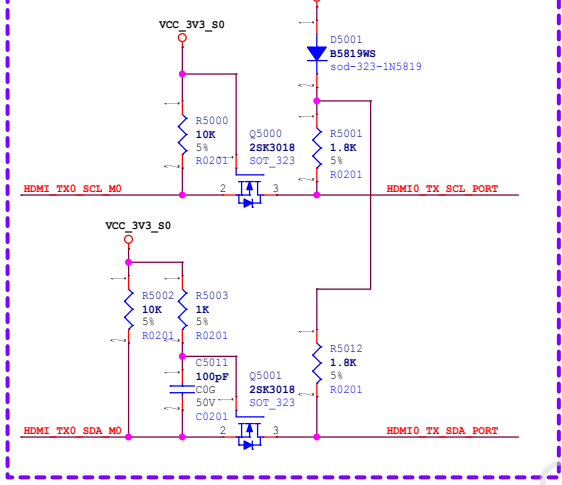

## HDMI TX CEC

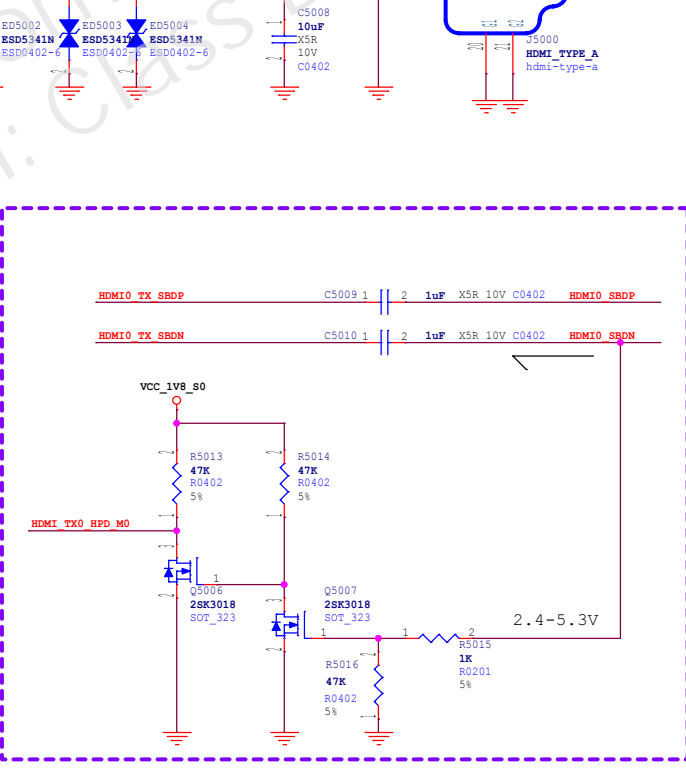
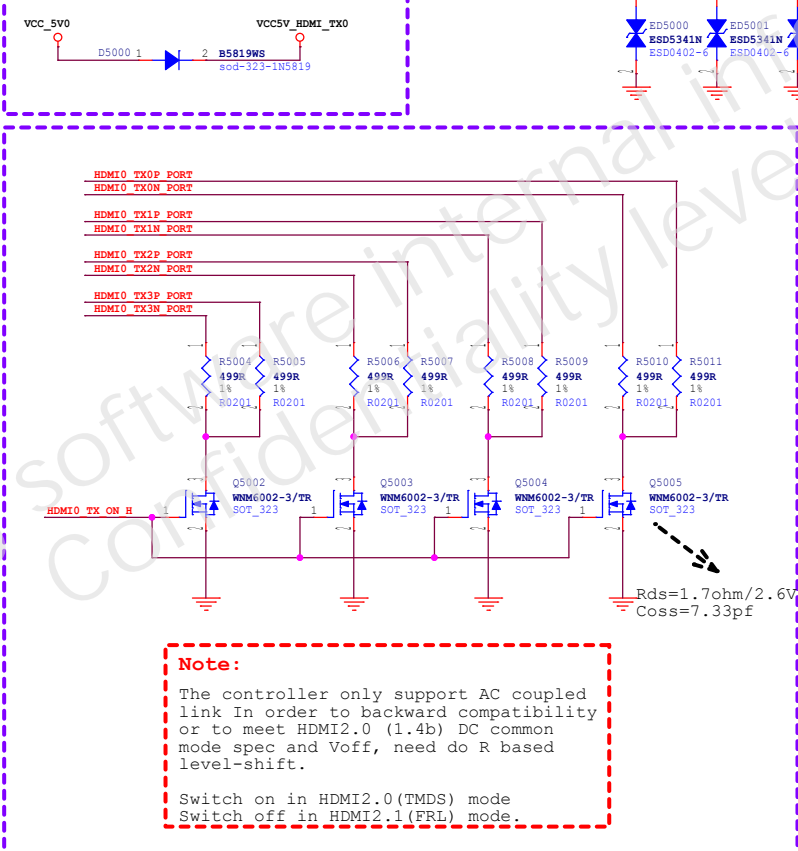
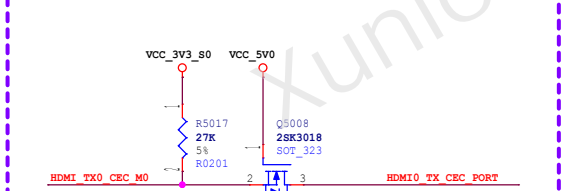

# MIPI DPHY TX

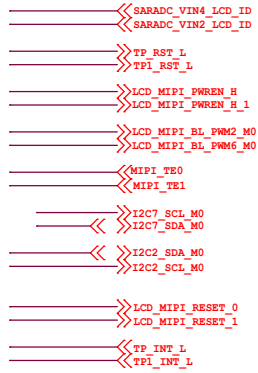

# MIPI DPHY0 TX

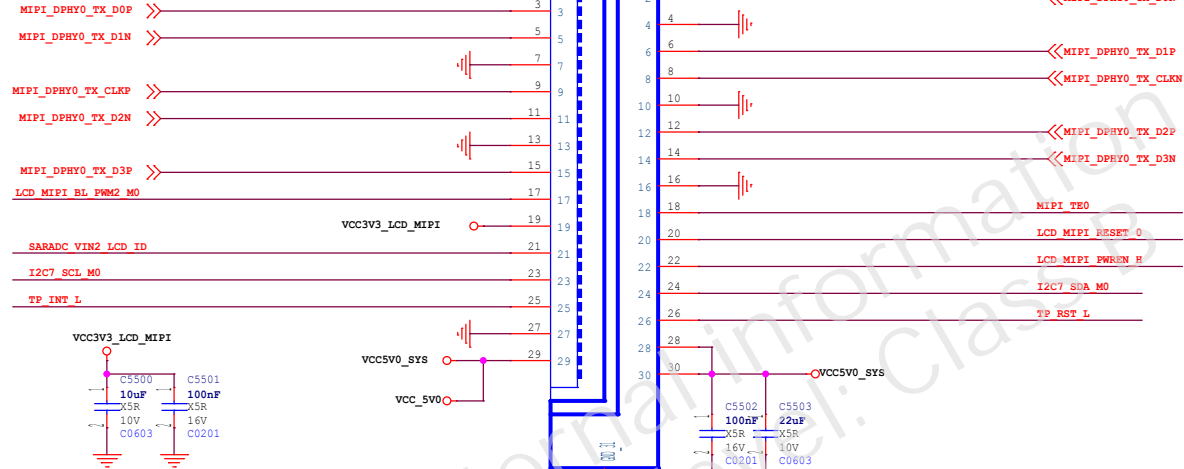

FPC Pin List	
Pin1	:GND
Pin2	:DON
Pin3	:D0P
Pin4	:GND
Pin5	:D1N
Pin6	:D1P
Pin7	:GND
Pin8	:CLKN/AUXN
Pin9	:CLKP/AUXP
Pin10	:GND
Pin11	:D2N
Pin12	:D2P
Pin13	:GND
Pin14	:D3N
Pin15	:D3P
Pin16	:GND
Pin17	:LCD_PWM_BL
Pin18	:LCD_TE
Pin19	:VCC3V3_LCD
Pin20	:LCD_RST
Pin21	:LCD_ID
Pin22	:LCD_PWREN
Pin23	:TP_I2C_SCL
Pin24	:TP_I2C_SDA
Pin25	:TP_INT
Pin26	:TP_RST
Pin27	:GND
Pin28	:5V0
Pin29	:5V0
Pin30	:5V0

# MIPI DPHY1 TX

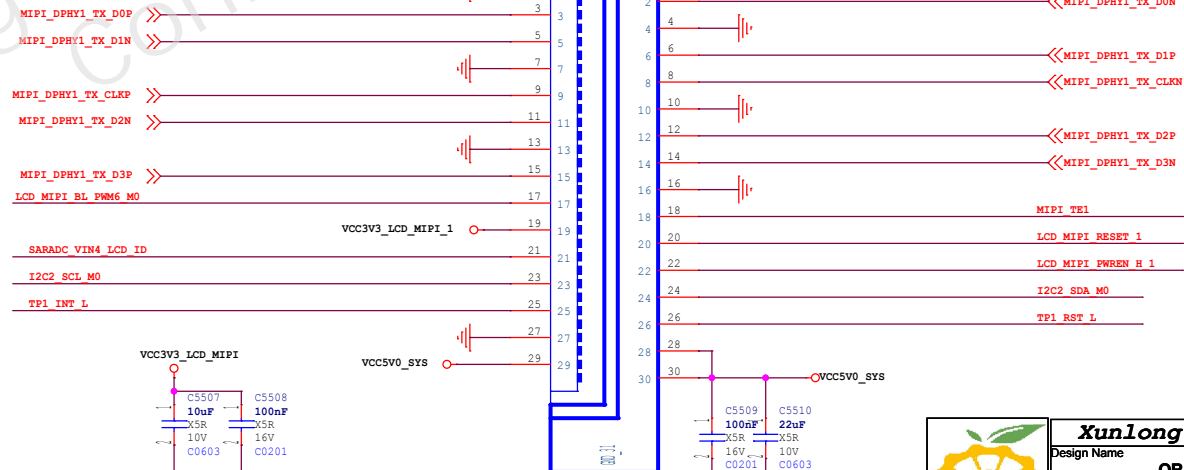

FPC Pin List	
Pin1	:GND
Pin2	:DON
Pin3	:D0P
Pin4	:GND
Pin5	:D1N
Pin6	:D1P
Pin7	:GND
Pin8	:CLKN/AUXN
Pin9	:CLKP/AUXP
Pin10	:GND
Pin11	:D2N
Pin12	:D2P
Pin13	:GND
Pin14	:D3N
Pin15	:D3P
Pin16	:GND
Pin17	:LCD_PWM_BL
Pin18	:LCD_TE
Pin19	:VCC3V3_LCD
Pin20	:LCD_RST
Pin21	:LCD_ID
Pin22	:LCD_PWREN
Pin23	:TP_I2C_SCL
Pin24	:TP_I2C_SDA
Pin25	:TP_INT
Pin26	:TP_RST
Pin27	:GND
Pin28	:5V0
Pin29	:5V0
Pin30	:5V0

**Xunlong Co., Limited**

Design Name: **ORANGEPI 5**

Size: A3	Page Name: VO-MIPI DPHY0/1-TX	Rev: 1.2
Date: Tuesday, November 08, 2022		
Sheet		30 of 36

# 10M/100M/1000M ETH

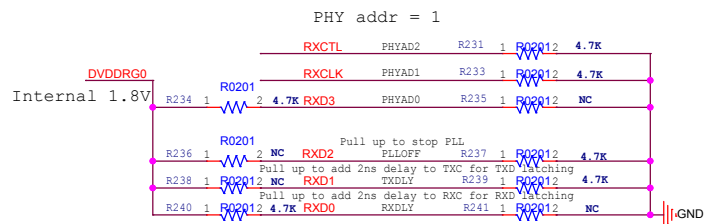
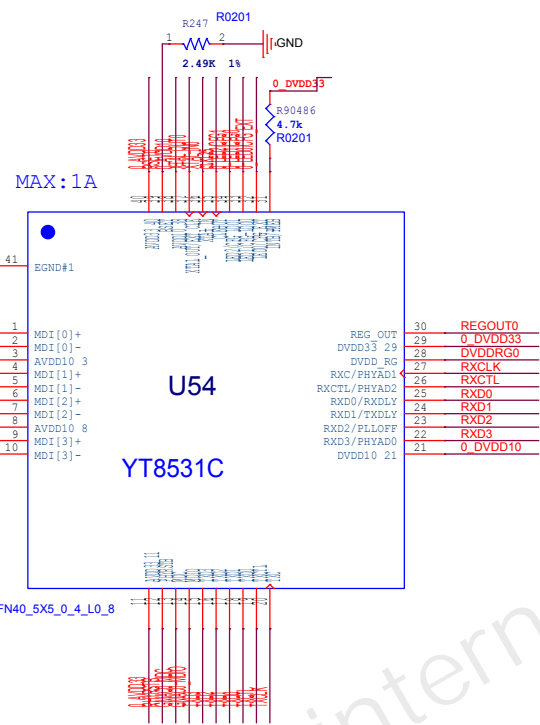
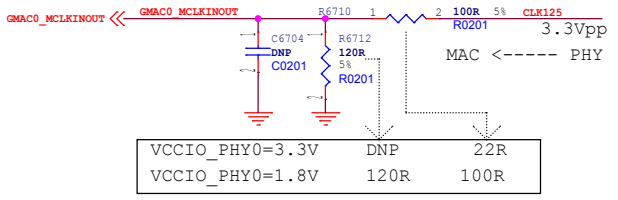

RGII Power Source	CFG_EXT	CFG_LDO[1:0]	CFG_EXT:
External 3.3V	1'b1	2'b00	1: External Power Source for IO pad.
External 1.8V (default)	1'b1	2'b10	0: Integrated LDO for IO pad
Internal 1.8V	1'b0	2'b10	CFG_LDO(1:0) 10: 1.8V 00: 3.3V

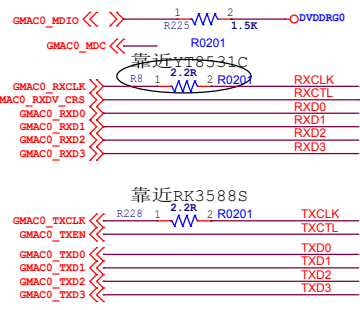

Differential pairs  
Z0= 100 ohm

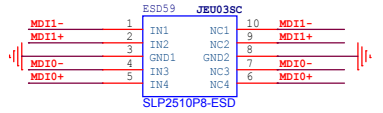
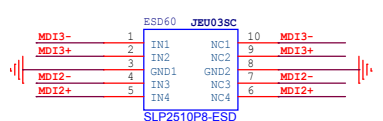
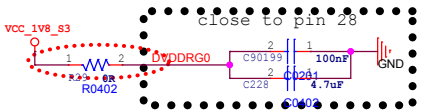
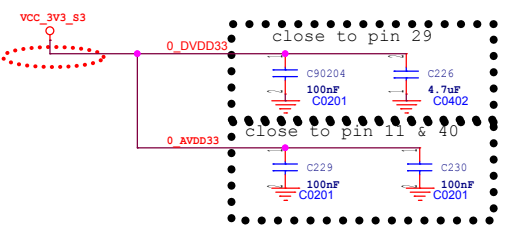
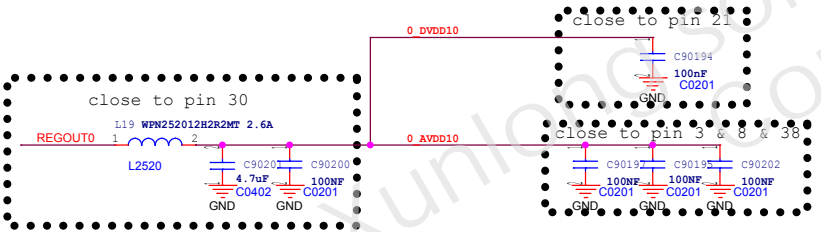
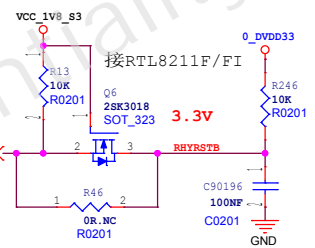
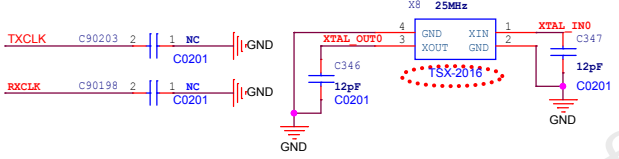
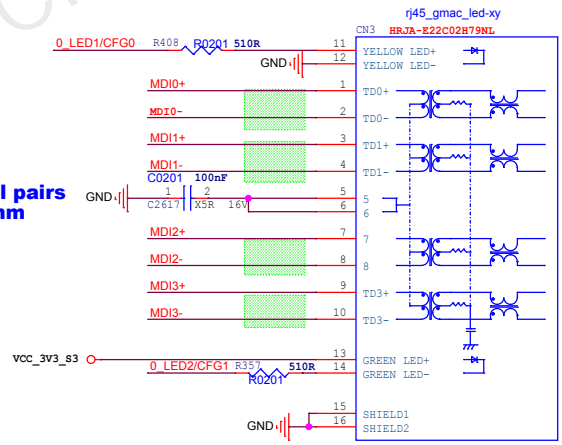

# M.2\_PCIe\_SATA/WIFIBT\_ Interface

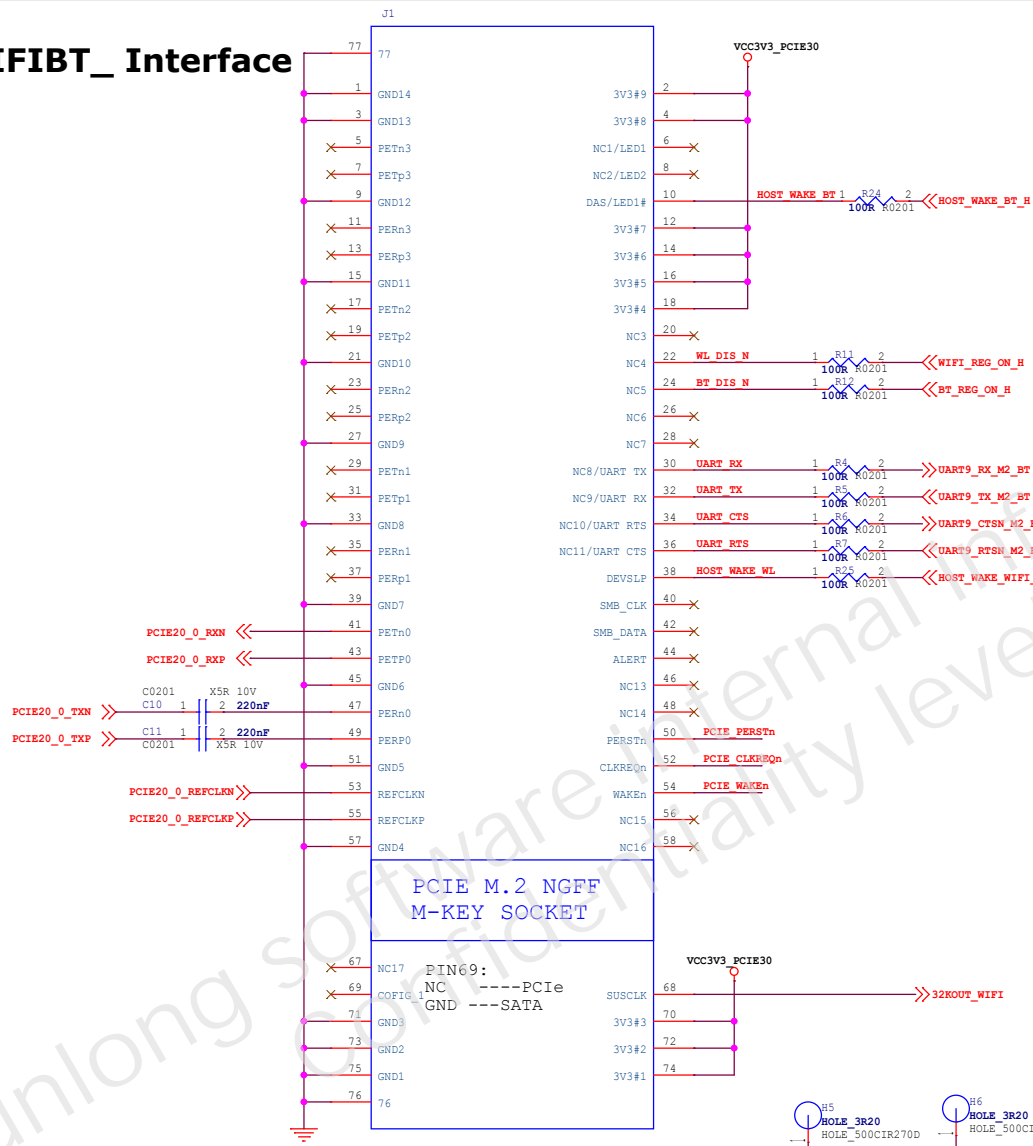

Socket 2 (B key-ngff) 和 Socket 3 (M key-nvme)

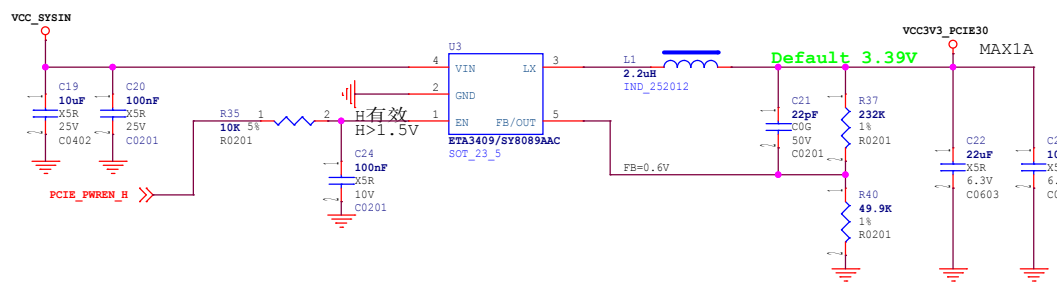
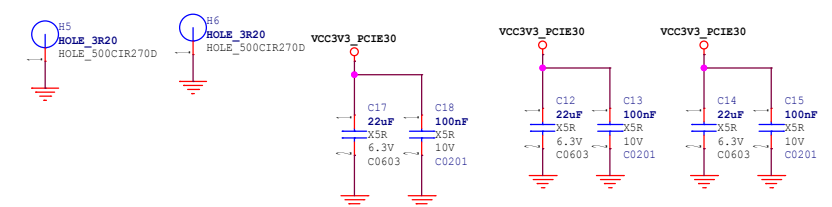
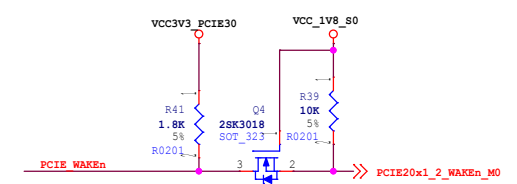
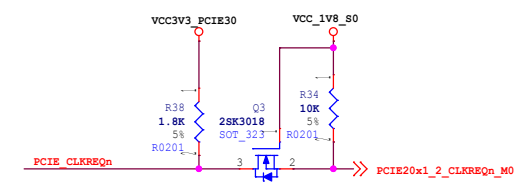
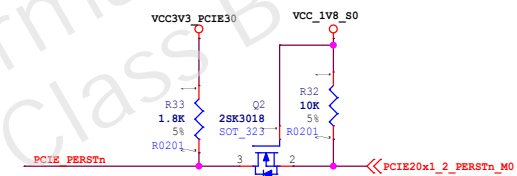





# EXT I/O

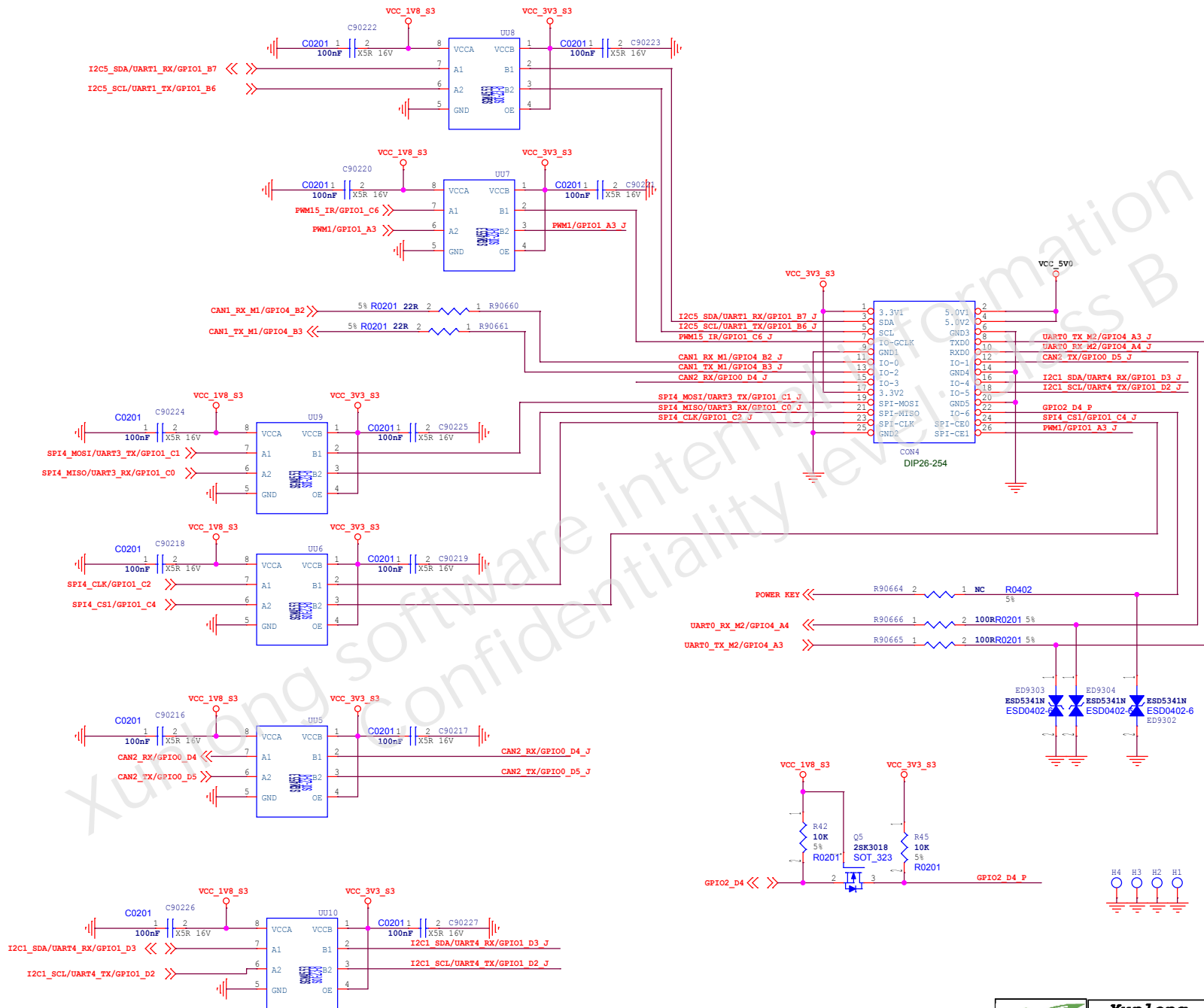

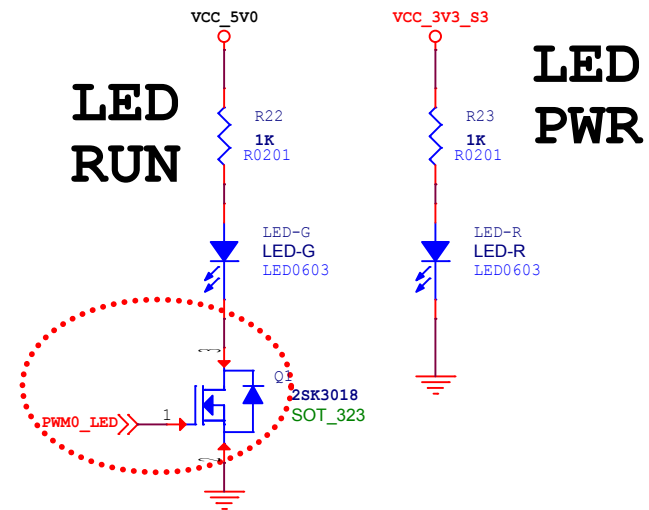
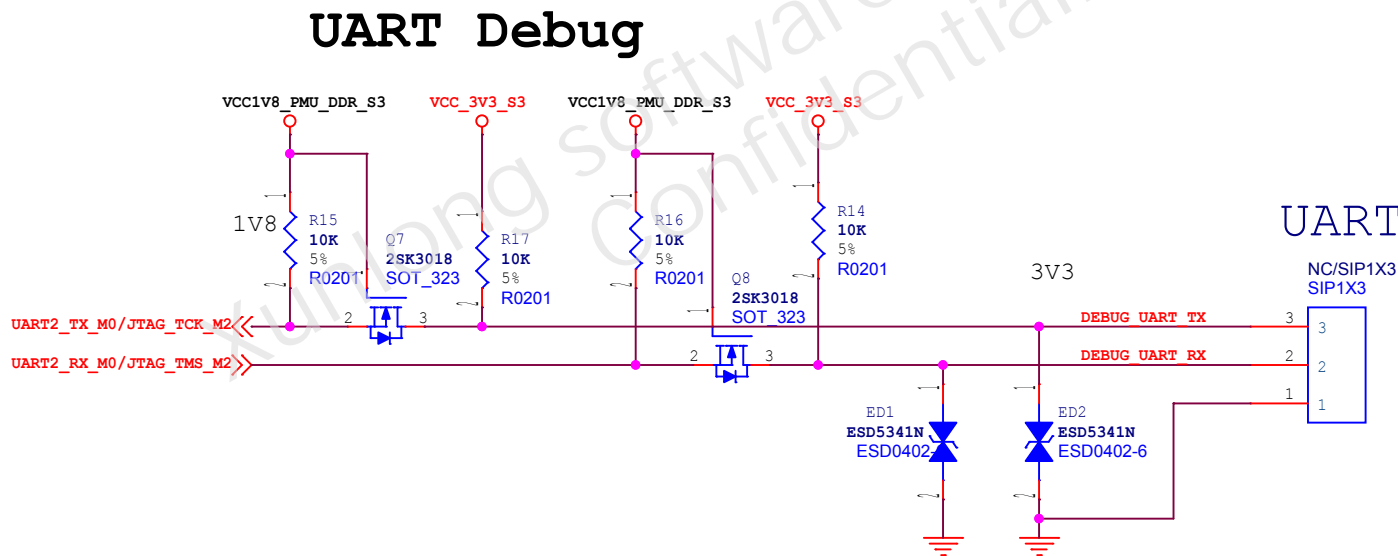
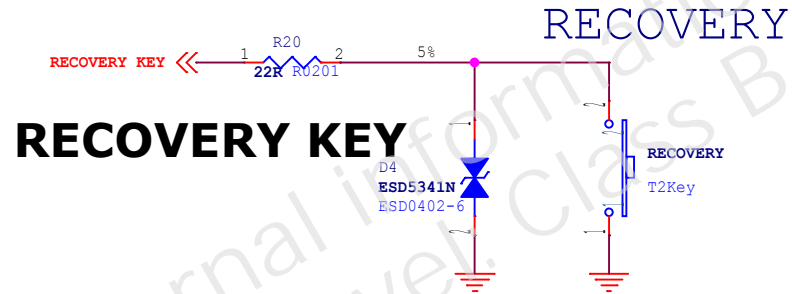
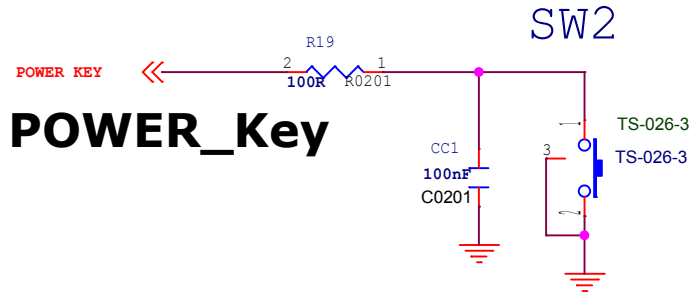
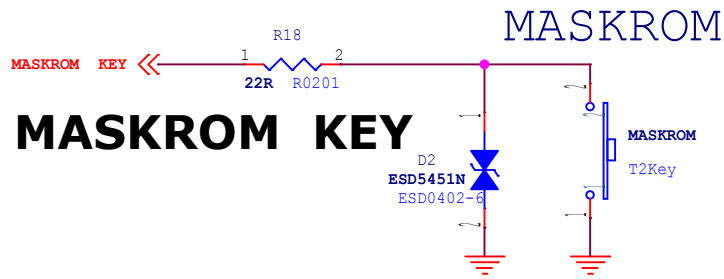

<b>Xunlong Co., Limited</b>		
Design Name <b>ORANGEPI 5</b>		
Size A4	Page Name <b>KEY</b>	Rev 1.2
Date: Tuesday, November 08, 2022 Sheet 35 of 36		

# SPI FLASH

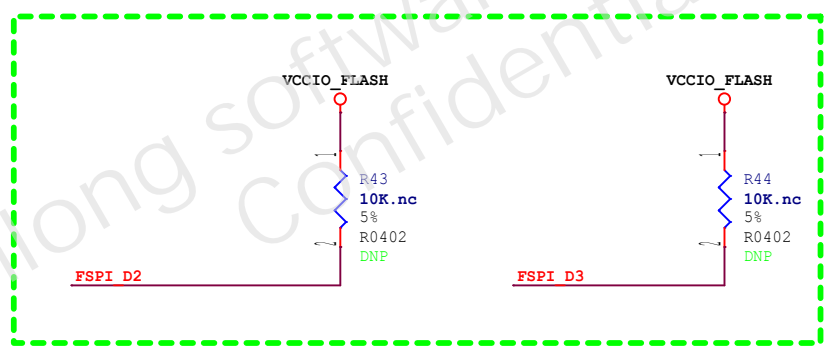
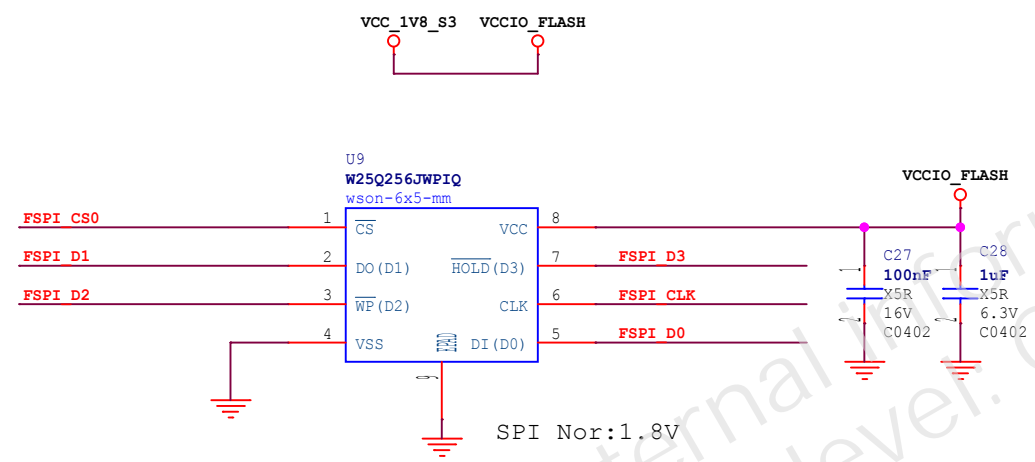
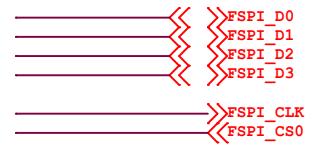

**Note:**  
When using SPI FLASH with only 1 bit, it needs to be stuffed.



<b>Xunlong Co., Limited</b>			
Design Name			
<b>ORANGEPI 5</b>			
Size A4	Page Name <b>KEY</b>		Rev 1.2
Date:	Tuesday, November 08, 2022	Sheet	36 of 36