

Product Reference Manual (V1.2)

Description

The UNIT DualMCU-ONE by UNIT Electronics is a highly versatile development board that combines the capabilities of ESP32 and RP2040 microcontrollers. Designed for advanced projects, it offers enhanced connectivity, robust power management, and full compatibility with Arduino UNO shields.

The DualMCU-ONE board enhances its predecessor DUALMCU by integrating SPI communication between the MCUs and incorporating a USB Type-C hub in place of the traditional USB communication switch. Additionally, it features direct CAN bus connectivity, enabling robust and efficient communication in automotive and industrial environments.

This combination of features makes the UNIT DualMCU-ONE an essential tool for developing demanding applications that require advanced connectivity and the ability to handle multiple communication protocols. It offers flexibility with programming languages such as C/C++, MicroPython, and CircuitPython.

Arduino UNO format compatibility.

This versatile board, formatted like the Arduino UNO, integrates dual 32-bit microcontrollers — the RP2040 operates at 133 MHz and the ESP32 at 240 MHz — within a compact 53mm x 68mm PCB.

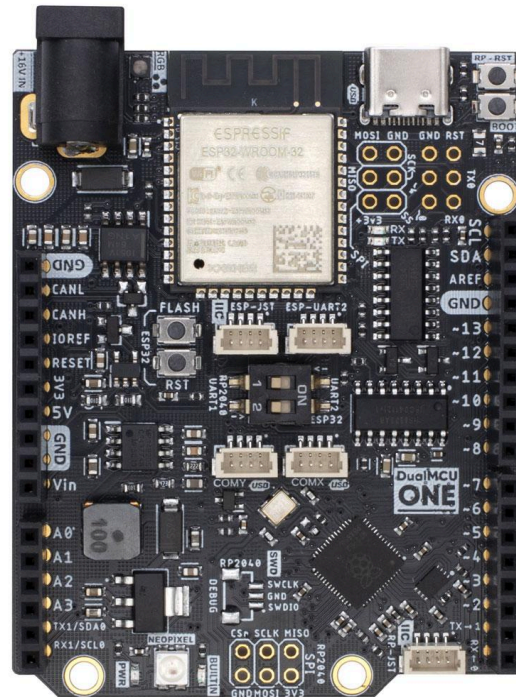

RP2040: Is the central core connected to the pin headers, enabling the DualMCU-ONE to maintain full pin compatibility with Arduino UNO shields, facilitating easy upgrades to existing projects (see Table 4.3.1).

ESP32: Provides Wi-Fi, Bluetooth, and CAN bus capabilities.

The DualMCU-ONE board is fully supported in the **Arduino development environment for both microcontrollers**, ensuring seamless integration with existing Arduino projects and libraries. For details on the Arduino packages for each microcontroller, **see Section 5.1.**

Enhanced Communication and Connectivity Between MCUs

UART & SPI: To ensure robust communication between the RP2040 and ESP32 microcontrollers, a dual-interface approach has been implemented:

- UART interface:** The primary connection leverages a UART link, where the UART0 of the RP2040 is connected to the UART2 of the ESP32. A DIP switch facilitates this connection by physically linking the TX pin of one microcontroller to the RX pin of the other, and vice versa, (see Table 3.12.1). ***This modular setup allows for easy reconfiguration or isolation of the UART connection as needed, enhancing flexibility during development and testing.***
- SPI interface:** Additionally, to address potential limitations in data transfer speed and reliability associated with UART communication, a **high-speed SPI interface** has been integrated between the two microcontrollers. This SPI implementation significantly improves the overall performance of the system by offering faster data exchange rates and more robust error handling mechanisms. For further details, **refer to Table 3.13.1**, which outlines the pin mappings and configurations used in this setup.

The combination of UART for basic communication and SPI for high-speed data transfer ensures seamless and reliable interaction between the RP2040 and ESP32, enabling more complex and data-intensive applications. For example, the ESP32 can operate as a wireless co-processor, providing the RP2040 microcontroller with Wi-Fi or Bluetooth connectivity, while concurrently managing CAN BUS communication. This configuration enables simultaneous processes where the ESP32 handles communication tasks, while the RP2040 focuses on other operations.

USB Hub Integration: The traditional USB communication switch found in the original ([DUALMCU](#)) has been replaced with a **USB Type-C hub** based on the HS8836A, enabling simultaneous connections to both the RP2040 and ESP32 microcontrollers using a single USB Type-C cable.

This hub simplifies the design by consolidating USB communication into one interface, enhancing usability and reducing cable clutter.

In addition to supporting the two microcontrollers, the hub provides connectivity for **two additional USB devices** through **JST connectors** with a 1 mm pitch. Each JST connector includes pins for **+VUSB, D-, D+, and GND** (see schematic at the end of the document), enabling direct communication with peripheral devices.

These connectors allow users to extend the functionality of the system by connecting USB-powered devices such as:

- **Human Interface Devices (HIDs):** A USB mouse or keyboard can be connected, enabling interactive applications like user interface navigation or data input.
- **Development Boards:** Smaller USB-enabled boards, such as a DualMCU, Seeed Studio Xiao or Adafruit Boards, can be integrated into the system to perform additional specialized tasks.
- **Sensors or Modules:** USB-enabled modules, such as a USB camera, temperature sensor, or GPS receiver, can be connected for advanced sensing or positioning capabilities.

This setup ensures that all devices connected via the JST connectors are powered and managed through the same Type-C cable that links the DUALMCU to a host computer. The seamless integration provided by the HS8836A hub enhances the system's versatility, enabling complex setups without requiring additional USB ports or cables.

For further details on the functionality of the JST connectors, refer to **Section 4.7 - Auxiliary JST Connectors (1mm Pitch) for USB**. Additionally, consult the schematic at the end of this document for a clear overview of the electrical connections and layout.

I2C Connectors:

Easily connect a wide range of I2C devices using the board's **STEMMA** and **QWIIC-compatible JST-SH I2C connectors**. These connectors feature a **1 mm pitch and 4 pins** (+V, GND, SDA, and SCL), ensuring compatibility with a variety of sensors and modules. Each microcontroller has its own dedicated QWIIC connector for enhanced flexibility:

- For the **RP2040**, refer to **Table 4.4.2 - RP2040 I2C-QWIIC Connector** for pin mappings.
- For the **ESP32**, refer to **Table 4.5.3 - ESP32 I2C-QWIIC Connector** for detailed configurations.

This modular setup simplifies the integration of peripherals, allowing developers to focus on project functionality without worrying about hardware compatibility.

Dynamic Visual Feedback:

To enhance interactivity and improve user experience, the board includes onboard **RGB 2020**, **WS2812B**, and **0603 LEDs**. These LEDs provide versatile visual feedback, ideal for a range of applications:

- **Status Indications:** Real-time feedback on system states, such as power, connectivity, or processing activity.
- **Visual Alerts:** Notifications for specific events or errors during operation.
- **User Interaction:** Dynamic visual effects to make projects more engaging and intuitive.

The onboard LEDs include:

- **L1 - Power On LED:** Indicates that the board is powered on, ensuring the system is receiving power.
- **L2 - Built-in LED:** Typically used for basic operation feedback, such as indicating a boot process or active state of the board.
- **L3 - TX LED:** Lights up when data is being transmitted, providing visual feedback of UART communication from the ESP32 microcontroller.
- **L4 - RX LED:** Lights up when data is being received, providing visual feedback of UART communication to the ESP32 microcontroller.
- **L5 - RGB-2020 LED:** Used for more dynamic and customizable feedback, capable of displaying multiple colors for status alerts or visual effects.
- **L6 - WS2812B-3030 LED:** A high-performance LED used for complex lighting effects, offering full RGB control and the ability to create colorful patterns or animations.

These LEDs are discussed in more detail in the following sections:

- **Section 3.2** - Board Topology
- **Section 3.7** - RGB LED
- **Section 3.8** - WS2812B LED

Micro SD:

The DualMCU-ONE board includes a Micro SD socket (**X1, refer to Table 3.2.2**) among its available connectors, supporting high-capacity memories up to 64 GB (tested). This socket is directly connected to the ESP32 microcontroller via QSPI communication, offering data transfer speeds up to four times faster than its predecessor, the DualMCU. This improvement provides more efficient data handling, making it ideal for projects requiring large storage and rapid data access.

The Micro SD socket, model [THD2528-11SD-GF](#), can be soldered directly onto the bottom side of the board. Please note that this socket is not pre-installed on the DualMCU-ONE board. However, end users can purchase the socket separately and solder it onto the designated pads, offering flexibility for those who wish to utilize this feature.

FPC-24P connector for ESP32 MCU

With a 24-pin FPC connector like the [AFC01-S24FCC](#) or [AFC07-S24ECC](#) (X2 on the PCB; see Table 3.2.2 - Rear View), available separately, the board's connectivity can be greatly expanded. This connector can be soldered onto the back of the DualMCU-ONE, providing direct access to most of the ESP32 microcontroller's pins. It offers developers a practical and efficient solution to fully leverage the system's potential.

The addition of the FPC connector is ideal for projects requiring additional external connections or the development of custom modules, such as displays, sensors, or port expanders. This versatility enables a

wide range of applications, from advanced prototypes to final solutions, without compromising the compact and functional design of the DualMCU-ONE board.

Robust Power Supply:

The DualMCU-ONE board features a robust power supply based on the MP1482DS integrated circuit. Unlike the traditional Arduino UNO, the DualMCU-ONE can support a maximum input voltage of 18V, thanks to this advanced regulator. The MP1482DS ensures efficient power conversion, delivering greater power and higher current output at 5V. This enhancement provides more stability and flexibility for demanding projects, allowing the DualMCU-ONE to power more peripherals and complex circuits without compromising performance.

CAN Bus Connectivity:

The DualMCU-ONE board includes CAN bus connectivity through the ESP32 microcontroller, which is equipped with a TCAN1051HVD transceiver. This setup allows for direct connection to a CAN bus, with CAN HIGH, CAN LOW, and GND available on the female headers. The TCAN1051HVD is a high-speed CAN transceiver that operates at data rates up to 1 Mbps and is suitable for working with a 3.3V I/O voltage range, ensuring compatibility with the ESP32. This integration provides reliable and efficient communication in automotive and industrial environments, making the DualMCU-ONE a powerful tool for applications requiring robust CAN bus connectivity. **For more details, refer to Sections 3.6 and 4.5.**

Support:

In addition to support for the Arduino IDE, the DualMCU-ONE board is compatible with the Raspberry Pi C/C++ SDK, specifically for C development on the RP2040 microcontroller. For Python-based projects, integrated development environments (IDEs) such as Thonny can be used, enabling work with MicroPython and CircuitPython on both microcontrollers, the RP2040 and the ESP32.

Additionally, for the ESP32, the DualMCU-ONE is compatible with advanced tools like Espressif IDE, expanding development options with dedicated support for the Espressif ecosystem. This flexibility makes the DualMCU-ONE a robust and versatile solution, ideal for developers looking to fully leverage the combined capabilities of both microcontrollers on a single development board.

Applications of the DualMCU-ONE

The **DualMCU-ONE** has been designed with both beginners and advanced users in mind, offering a versatile and powerful experience that adapts to any skill level.

Arduino Uno Compatibility

If you are just starting to explore electronics or already have experience working with Arduino Uno, the **DualMCU-ONE** is the perfect choice for you. Its pin distribution on the female headers is fully compatible with that of Arduino Uno, ensuring that you can use most shields designed for that platform without making significant changes to your existing code.

This means you can easily replace your Arduino Uno board with the **DualMCU-ONE** and enjoy its extensive compatibility, while keeping in mind that the **DualMCU-ONE** operates with 3.3V logic levels instead of Arduino Uno's typical 5V.

Greater Power and Possibilities

By integrating the **RP2040** microcontroller instead of the ATmega328P, the **DualMCU-ONE** significantly expands the capabilities of your projects:

- **32-bit Processor:** Dual-core ARM Cortex-M0+ with a clock speed of up to 133 MHz.
- **DMA and PIO (Programmable I/O):** Offload tasks from the processor for more efficient performance.
- **Interconnection with ESP32:** Another 32-bit microcontroller connected via SPI, adding **Wi-Fi**

and **Bluetooth** wireless capabilities and functioning as a co-processor.

For Beginners and Experts

- **Beginners:** You can use the **DualMCU-ONE** as easily as an Arduino Uno board. All your Arduino code will work seamlessly, removing any technical barriers.
- **Advanced Users:** The board offers incredible potential thanks to its advanced features, such as four programmable cores, wireless communication, CANBUS support, and low power consumption, enabling more complex and ambitious projects.

Application Areas

The **DualMCU-ONE** is perfect for a wide range of applications:

- **Education:** Ideal for students and makers who want to learn about advanced microcontrollers while maintaining the simplicity of the Arduino environment.
- **Internet of Things (IoT):** Its built-in wireless capabilities make it an excellent choice for developing connected devices.
- **Prototyping:** Its features allow for rapid and efficient prototyping with a compact and versatile design.
- **Machine Learning:** Its processing power supports exploring basic machine learning models and advanced tasks.

- **Robotics:** With multiple pins and advanced processing capabilities, it is ideal for robotics projects

requiring motor control, sensors, and advanced communications.

- **Advanced Projects:** Its compatibility with Arduino Uno shields and additional features make it a powerful tool for designing final solutions.

With the **DualMCU-ONE**, both beginners and experts can unlock the full potential of working with two advanced microcontrollers on a single board, taking their projects to the next level.

Features

Raspberry Pi RP2040 Microcontroller

- 133MHz 32bit Dual Core Arm® Cortex®-M0+
- 264kB on-chip SRAM
- Direct Memory Access (DMA) controller
- Support for up to 16MB of off-chip Flash memory via dedicated QSPI bus
- Programmable IO (PIO) for extended peripheral support
- 30 GPIO pins, 4 of which can be used as analog inputs
- 4 channel ADC with internal temperature sensor, 0.5 MSa/s, 12-bit conversion
- 16 PWM channels
- SWD Debugging
- 2 UARTs
- 2 SPI controllers
- 2 I2C controllers
- 8 PIO state machines
- USB 1.1 controller and PHY, with host and device support
- 2 on-chip PLLs to generate USB and core clock
- 40nm process node
- Multiple low power mode support
- Internal Voltage Regulator to supply the core voltage
- Advanced High-performance Bus (AHB)/Advanced Peripheral Bus (APB)

Memory

- W25Q16JVUXIQ 2MB NOR Flash
- 532MHz Quad SPI
- 66MB/S continuous data transfer rate
- 100K program/erase cycles
- More than 20-year data retention

Espressif ESP32 WROOM 32

Wi-Fi/Bluetooth® Module

- 240MHz 32bit Dual Core Xtensa LX6
- 520kB on-chip SRAM
- 448 Kbyte ROM for booting and core functions
- 8 MB Integrated SPI flash
- 1 kbit EFUSE (non-erasable memory) for MAC addresses, module configuration, Flash-Encryption, and Chip-ID
- IEEE 802.11b/g/n (802.11n up to 150 Mbps) single-band 2.4 GHz Wi-Fi operation, center frequency range of operating channel (2412 ~ 2484 MHz)
- Bluetooth® 4.2 BR/EDR and Bluetooth LE specification, NZIF receiver with -97 dBm sensitivity, Class-1, class-2 and class-3 transmitter, AFH
- +12 dBm transmitting power, the internal PCB antenna in the module eliminates the need for an external antenna
- ADC, I2C, SDIO, QSPI, UART, I2S, Two-Wire Automotive Interface (TWAi®), compatible with ISO11898-1 (CAN Specification 2.0)
- On-chip Hall Sensor

WS2812B-3030 LED

- RGB NeoPixel for full color indication
- Connected to RP2040 GPIO (24)

RGB-2020 LED

- Common Anode
- Connected to ESP32 GPIO (25, 26, 27)

Built-in LED

- LED for general purpose blinking, connected to RP2040 GPIO25

MicroSD CARD

- Connected to ESP32 vía QSPI GPIO(2,4,12,13,14,15)

I/O

- From the RP2040: 13 digital pins and 4 analog pins (compatible with the Arduino UNO pinout), plus additional pins from the ESP32 MCU.
- 3 x UART peripherals (2 UARTs in the RP2040 and 1 in the ESP32)
- 3 x SPI (two from RP2040 and one in the ESP32)
- 3 x I2C (Two of which have a JST-1.0 mm pitch on-board connectors, compatible with STEMMA QT and QWIIC devices)
- All digital pins of RP2040 can be driven by the PWM block
- All ESP32 pins digital outputs can be used as PWM pins (GPIOs 36 and 39 can't generate PWM)
- ESP32 CAN 2.0

Power

- Vin max 20 V over Jack connector (J2) for power supply
- 5V out max 2A efficient conversion (MP1482DS)
- 3.3 v LDO 800 mA

CAN BUS connectivity

- TCAN1051HVD high-speed CAN transceiver that operates at data rates up to 1 Mbps working at 3.3V I/O voltage range. Connected to GPIO25 y GPIO26 in the ESP32.

Connectors

- 2 x I2C JST-SH (1 mm pitch) (QWIIC standard connector, one for ESP32 microcontroller and the other one for the RP2040 microcontroller)

- 1 x UART JST-SH (1 mm pitch) for ESP32-UART2
- 1 Auxiliary microSD Card Holder
- 1 Auxiliary FPC-24P
- 1 USB Type C
- 2 x USB JST-SH (1 mm pitch). Direct connection of usb devices to the USB hub.
- 1 Optional JST-SH 3P (1 mm pitch) for RP2040 debugging
- 1 Jack connector for power supply (J2)

Communication and Connectivity

- USB Type-C hub (HS8836A)
- DIP Switch for UART communication
- Reset button and Bootloader select button for RP2040 quick restarts (no unplugging-replugging to relaunch code)
- ESP32 Reset button and Flash/Boot button for manually entering flash mode
- ESP32 2x3 pin header for SPI output
- ESP32 2x3 pin header for GPIO output and programming (IO0, IO4, TX0, RX0, RST, GND)
- RP2040 2x3 pin header for SPI output
- CANH, CANL and GND out available in the female header for direct CAN Bus connectivity and 120 ohm link resistor for bus impedance

OSC

- 12 MHz crystal for perfect timing for RP2040 microcontroller

CONTENTS

1 The Board

1.1 Accessories

2 Ratings

2.1 Recommended Operating Conditions

3 Functional Overview

3.1 Block Diagram

3.2 Board Topology

3.3 Processor

3.4 Wi-Fi/Bluetooth® Connectivity

3.5 External Memory

3.6 CAN BUS

3.7 RGB LED

3.8 WS2812B LED

3.9 MicroSD Card Socket

3.10 MP1482DS: Robust DC/DC Converter for Power Supply Management

3.11 USB HUB for the USB Communication

3.12 DIP Switch for UART Communication

3.13 SPI Communication Between MCUs (RP2040 and ESP32)

3.14 Power Tree

4 Connectors & Pinouts

4.1 General Top Side Pinout

4.2 General Bottom Side Pinout

4.3 Arduino UNO-Compatible Pinout on DualMCU-ONE (Connections to MCU RP2040)

4.4 RP2040 Debugging, QWIIC, and SPI Connectors

4.5 ESP32: SPI & UART Headers, I2C-QWIIC, JST-UART and CAN BUS Connectors

4.6 ESP32: Auxiliary MicroSD & FPC-24P Connectors

4.7 - Auxiliary JST Connectors (1mm Pitch) for USB

5 Board Operation

5.1 Getting Started with arduino IDE

6 Mechanical Information

7 Company Information

8 Reference Documentation

9 Appendix

9.1 Schematic

1 The Board

1.1 Accessories

USB type C cable

1x6-pin 2.54mm female headers

1x8-pin 2.54mm female headers

2x10-pin 2.54mm female headers

3x(2x3) 2.54mm male headers

2 Ratings

2.1 Recommended Operating Conditions

Symbol	Description	Min	Typ	Max	Unit
V _{IN}	Input voltage from VIN pin	7	12	20	V
V _{5v}	Output System Voltage (V _{sys})	4.6	5	5.5	V
I _{5v}	5V output current (MP1482DS) [◆]	1.5	1.8	2	A
V _{3v3}	3.3V output to user application	3.25	3.3	3.35	V
I _{3v3}	3v3 output current (including onboard IC)	600	800	1000	mA
V _{IH} (RP2040)	Input high-level voltage	2	-	3.6	V
V _{IL} (RP2040)	Input low-level voltage	-0.3	-	0.8	V
I _{OH} Max (RP2040)	Current at VDD-0.4v, output set high			8	mA
I _{OL} Max (RP2040)	Current at VSS+0.4v, output set low			8	mA
V _{OH} (RP2040)	Output high voltage, 8 mA	2.62	-	3.3	v
V _{OL} (RP2040)	Output low voltage. 8 mA	0	-	0.5	V
R _{PU} (RP2040)	Pull-Up Resistance	50	-	80	kΩ
R _{PD} (RP2040)	Pull-Down Resistance	50	-	80	kΩ
I _{IOVDD_MAX}	Maximum Total IOVDD current*			50	mA

(RP2040)					
IIOVSS_MAX (RP2040)	Maximum Total VSS current due to IO (IOVSS)**			50	mA
TOP (RP2040)	Operating temperature	-20	-	80	°C
VIH (ESP32)	Input high-level voltage	2.475	-	3.6	V
VIL (ESP32)	Input low-level voltage	-0.3	-	0.825	V
IOH Max (ESP32)	Current at VDD=3.3V, VOH >=2.64V, output set high***			40	mA
IOL Max (ESP32)	Current at VDD = 3.3 V, VOL =0.495 V, output set low			28	mA
VOH (ESP32)	Output high voltage	2.64	-	3.3	V
VOL (ESP32)	Output low voltage	-	-	0.33	V
RPU (ESP32)	Pull-Up Resistance	-	45	-	kΩ
RPD (ESP32)	Pull-Down Resistance	-	45	-	kΩ
TOP (ESP32)	Operating temperature	-40	-	85	°C

* Sum of all current being sourced by GPIO and QSPI pins

**Sum of all current being sunk into GPIO and QSPI pins

***Per-pin current sourced in the same domain is gradually reduced from around 40 mA to around 29 mA, VOH>=2.64 V, as the number of current-source pins increases

◆ When operating at **2A**, the MP1482DS requires the implementation of **heat dissipation** or **proper cooling** to ensure safe operation.

- If the component temperature reaches **150°C**, thermal protection will activate, halting operation to prevent damage.

- To maintain optimal performance, it is recommended to add a heatsink or enhance airflow.

3 Functional Overview

The **UNIT DualMCU-ONE** is a cutting-edge development board that combines the ESP32 and RP2040 microcontrollers, offering unparalleled versatility for electronics projects. This board is designed to deliver robust connectivity, seamless integration, and compatibility with the Arduino UNO shield ecosystem.

Key features include a USB Type-C hub for simultaneous MCU connections, integrated CAN bus connectivity for industrial applications, and enhanced communication protocols like UART and SPI for efficient MCU intercommunication. The board also supports popular programming environments, such as Arduino IDE, MicroPython, CircuitPython, and the Raspberry Pi C/C++ SDK, ensuring flexibility for developers of all levels.

Designed with precision, the DualMCU-ONE enables direct access to essential features like I2C connectors, WS2812B and RGB LEDs for visual feedback, and optional expandable connectivity through an FPC-24P connector. A robust power management system allows for reliable operation across demanding applications, and its support for Micro SD storage ensures efficient data handling.

With its combination of advanced features, intuitive design, and compatibility with Arduino UNO shields, the UNIT DualMCU-ONE is the ideal solution for educational, IoT, prototyping, robotics, and machine learning projects, catering to both beginners and experts alike.

3.1 Block Diagram

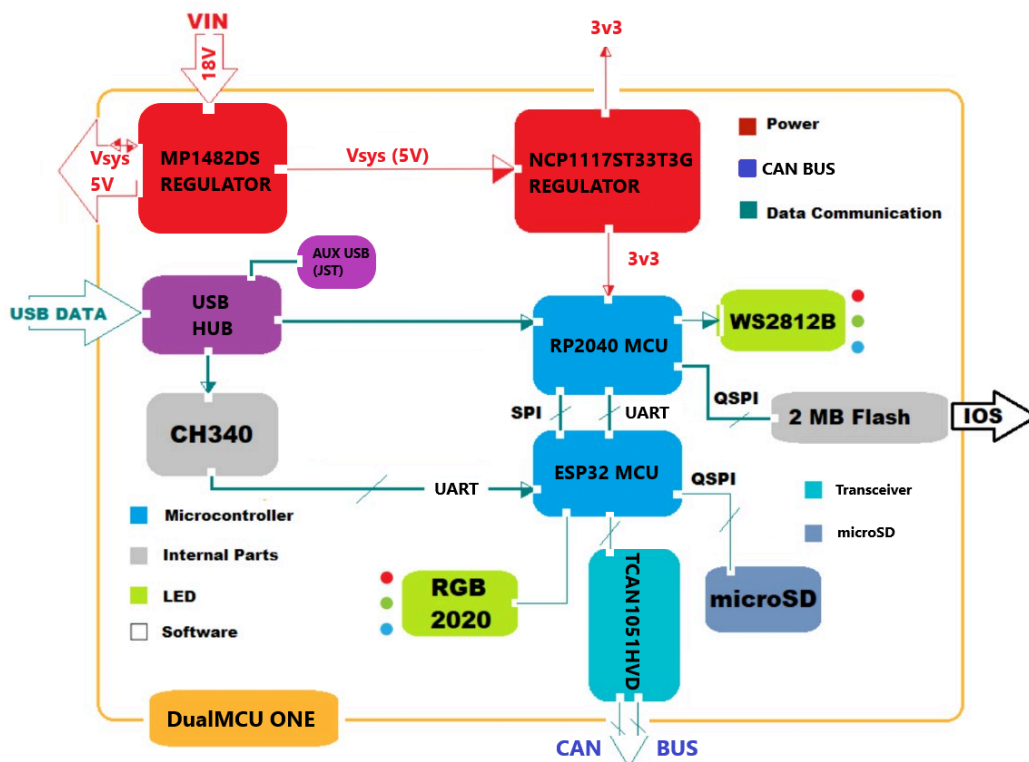

Block Diagram of DualMCU-ONE RP2040 + ESP32

3.2 Board Topology

Front View

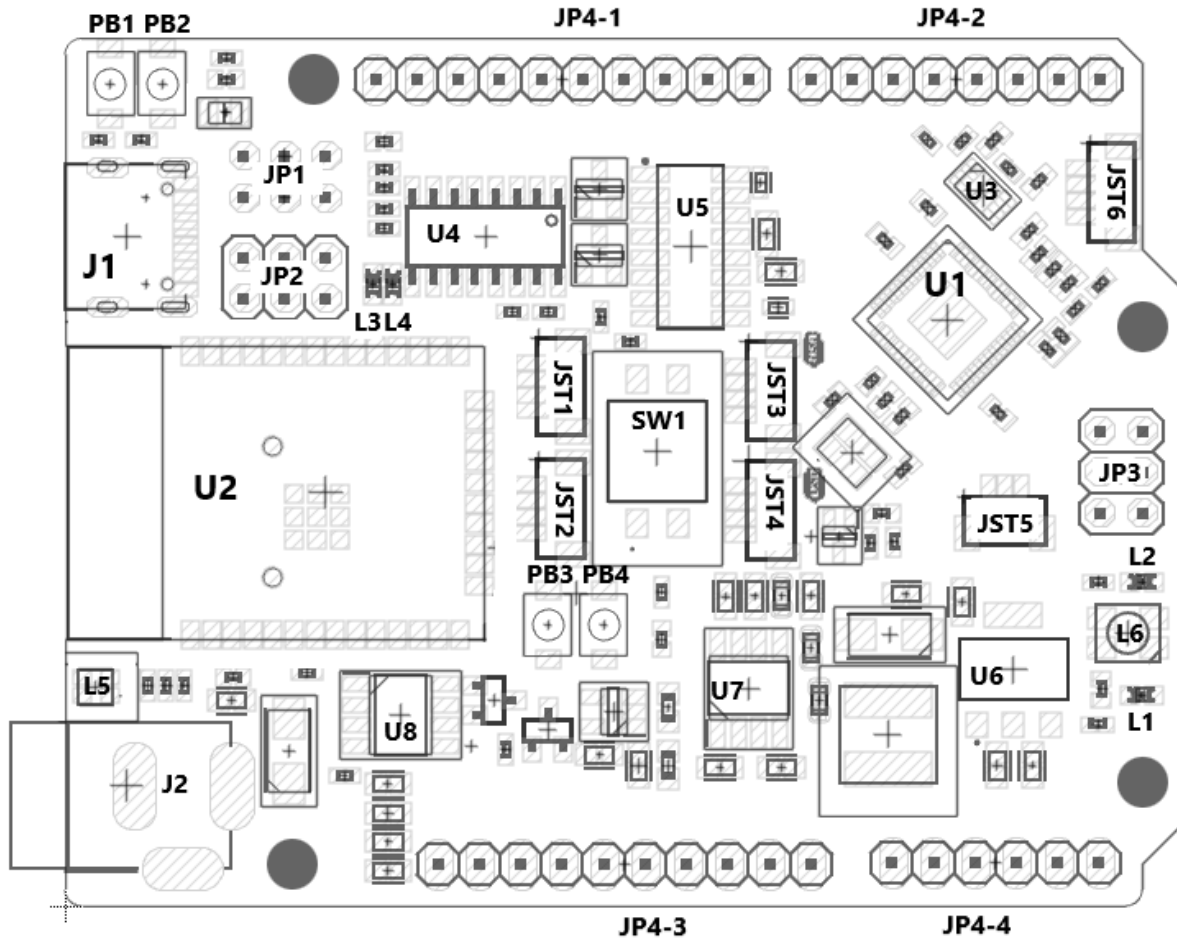

Front View of DualMCU-ONE RP2040 + ESP32 Topology

Table 3.2.1 - Components Overview: Front View

Ref.	Description	Ref.	Description
U1	Raspberry pi RP2040 Microcontroller	U4	CH340C USB bus convert IC
U2	Espressif ESP32 WROOM Wi-Fi/Bluetooth® Module	U5	HUB USB IC
U3	W25Q16JVUXIQ 2MB Flash IC	U6	NCP1117ST33T3G 3v3 LDO Voltage Regulator
U7	MP1482DS-LF-Z DC/DC Converter	U8	TCAN1051HVD CAN BUS Transceiver
L1	Power On LED	L2	Builtin LED
L3	TX LED	L4	RX LED

L5	RGB-2020 LED	L6	WS2812B-3030 LED
J1	Male USB Type C Connector	J2	Power Jack Connector
PB1	RP2040 Reset Button	PB2	RP2040 Boot Button
PB3	ESP32 Flash Button	PB4	ESP32 Reset Button
JP1	ESP32 SYSTEM AND UART Header	JP2	ESP32 SPI Header
JP3	RP2040 SPI Header	JP4	JP4-1,JP4-2,JP4-3,JP4-4: Female Headers 2.54mm, compatible with Arduino UNO Pinout
JST1	ESP32 UART JST Connector	JST2	ESP32 I2C-QWIIC JST Connector
JST3	AUX USB COMX JST Connector	JST4	AUX USB COMY JST Connector
JST5	RP2040 JST-3P Debugging Connector	JST6	RP2040 I2C-QWIIC JST Connector
SW1	UART DIP Switch		

Back view

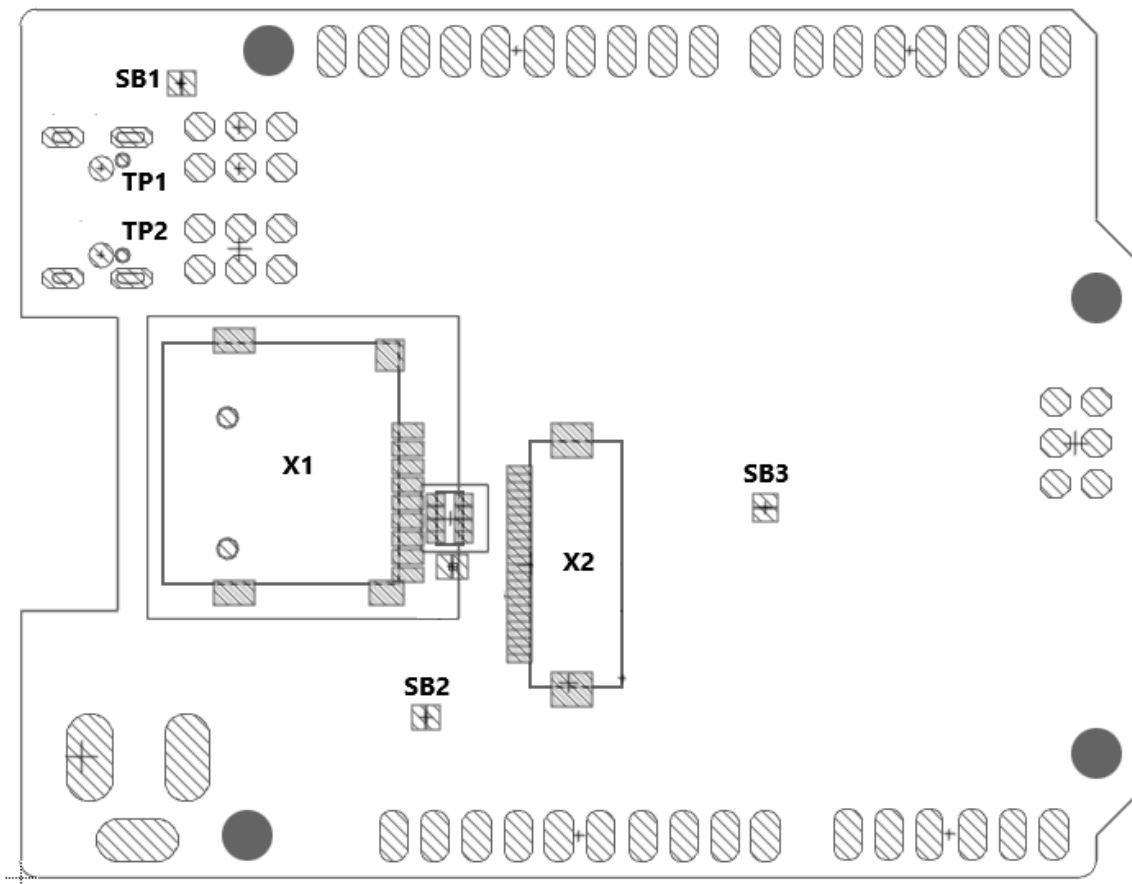

Back View of DualMCU-ONE RP2040 + ESP32 Topology

Table 3.2.2 - Components Overview: Back View

Ref.	Description	Ref.	Description
X1	Auxiliary MicroSD Card Connector	X2	Auxiliary FPC-24P Connector
SB1	RP2040 to ESP32_RST Solder Bridge (disconnected)	SB2	120R CAN BUS Resistor Solder Bridge (disconnected)
SB3	Steps ADC3 Leakage Solder Bridge (disconnected)	SB4	ESP32-IO14 to RP2040-GPIO15 Solder Bridge (Connected)
TP1	USB D- Test point	TP2	USB D+ Test point

3.3 Processor

The DualMCU-ONE is powered by the Raspberry Pi RP2040 microcontroller (U1), manufactured using a modern 40nm process. This is Raspberry Pi's debut microcontroller, known for its high performance and ease of use in embedded systems.

Key features include:

- **Memory:** Six independent banks of 264 KB SRAM, totaling a large on-chip memory.
- **CPU:** Dual symmetric Arm® Cortex®-M0+ processors clocked at 133 MHz.
- **Bus Fabric:** Deterministic bus fabric ensuring reliable performance.
- **Peripherals:** A rich peripheral set augmented by a unique Programmable I/O (PIO) subsystem.
- **Debugging:** Serial Wire Debug (SWD) support, accessible via the JST5-3P connector.
- **USB Interface:** USB 1.1 device interface for uploading code.
- **External Flash:** 2 MB off-chip Flash memory accessible via a dedicated QSPI bus.

The RP2040 also manages the digital pins and analog pins (A0–A3), as well as the I2C connections (SDA and SCL) on the JST6 QWIIC connector.

3.4 Wi-Fi/Bluetooth® Connectivity Module

The DualMCU-ONE integrates an Espressif ESP32 WROOM-32 (U2) module for Wi-Fi and Bluetooth® connectivity, with the CH340C (U4) USB-to-UART bridge IC enabling programming and communication via USB.

Key specifications include:

- **CPU:** Dual-core Xtensa LX6 clocked at up to 240 MHz.
- **Memory:** 512 KB on-chip SRAM and 8 MB SPI Flash memory.
- **Peripherals:**
 - Multiple programmable GPIOs.
 - ADC, I2C, UART, and Capacitive Touch Sensor.

- Two-Wire Automotive Interface (TWA[®]), compliant with ISO11898-1 (CAN Specification 2.0).
- **Pin connectors:** Interfaces are exposed through the JP1, and JP2 pin headers, as well as the auxiliary FPC-P24 connector (X2).

3.5 External Memory

The RP2040 (U1) accesses external 2 MB Flash memory (U3) via a QSPI interface. This external memory stores application code and data, utilizing execute-in-place (XIP) technology to run code directly from Flash without requiring RAM transfer.

3.6 CAN BUS

The **TCAN1051HVD** IC (U8) serves as the CAN transceiver, enabling the **ESP32** microcontroller to interface with the CAN bus, which is widely used in automotive and industrial applications for robust and efficient communication. The TCAN1051HVD is a high-speed CAN transceiver capable of operating at data rates up to 1 Mbps, providing reliable transmission of data in environments with high electromagnetic interference (EMI).

This IC is designed to handle the standard 3.3V logic levels of the ESP32 and ensures seamless integration with the **CAN bus**, which is essential for applications such as vehicle diagnostics, industrial control systems, and robotics. The transceiver supports both **CAN High** and **CAN Low** lines, as well as the **Ground** connection, making it a complete solution for communication on the CAN bus.

By utilizing this transceiver, the DualMCU-ONE board offers exceptional flexibility for developers working on automotive, industrial, or IoT applications that require reliable and efficient communication. For detailed information about the pin connections for CAN bus communication, refer to **Table 4.5.4**.

3.7 RGB LED

The common anode RGB-2020 LED (L5) is controlled by the ESP32 module. It lights up when the digital state is LOW and turns off when the state is HIGH. The ESP32 GPIOs connected to the LED are IO25, IO26, and IO27.



3.8 WS2812B LED

The WS2812B-3030 LED (L6) is an intelligent RGB NeoPixel designed for full-color indications. It is connected to the RP2040 via:

- GPIO24 for the digital input (DI).
- D28 when using in the Arduino environment.



3.9 MicroSD Card Socket

The ESP32 interfaces with a microSD card via the onboard socket (X1), utilizing a QSPI interface. This functionality is ideal for applications requiring large file storage beyond the ESP32's SPIFF (flash file system). The microSD card socket supports high-capacity memory cards up to 64 GB (tested), enabling efficient data storage for advanced applications such as data logging or multimedia handling.

Note: The microSD card socket (model THD2528-11SD-GF) is an auxiliary component that must be purchased separately. It can be soldered onto the designated pads on the bottom side of the DualMCU-ONE board.

For further details on connection mapping, refer to **Table 4.6.1**.

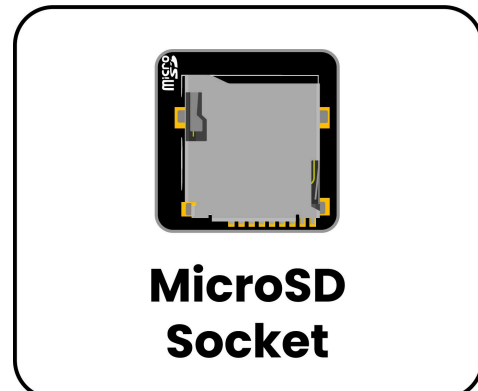

3.10 MP1482DS: Robust DC/DC Converter for Power Supply Management

The MP1482DS-LF-Z (U7) integrated circuit provides a robust and efficient DC/DC conversion system for powering various components on the board. Unlike traditional Arduino UNO boards, the DualMCU-ONE can accept input voltages of up to 18-20V, offering greater flexibility in power supply options.

This high-performance regulator ensures stable 5V output and supports higher current demands (2A), enabling the board to power multiple peripherals and complex circuits without compromising performance. The MP1482DS provides enhanced power management, making the board ideal for demanding projects requiring robust and reliable power delivery.

3.11 USB HUB for the USB Communication

The USB HUB (HS8836A) (U5) replaces the traditional USB communication switch found in the original DUALMCU board. This advanced hub allows simultaneous connections to both the RP2040 and ESP32 microcontrollers through a single USB Type-C connector, significantly simplifying the development process.

Additionally, the USB HUB supports two external USB devices via JST connectors with a 1 mm pitch. This feature expands the board's connectivity options, making it versatile for advanced setups involving additional USB peripherals, such as external storage or input devices.

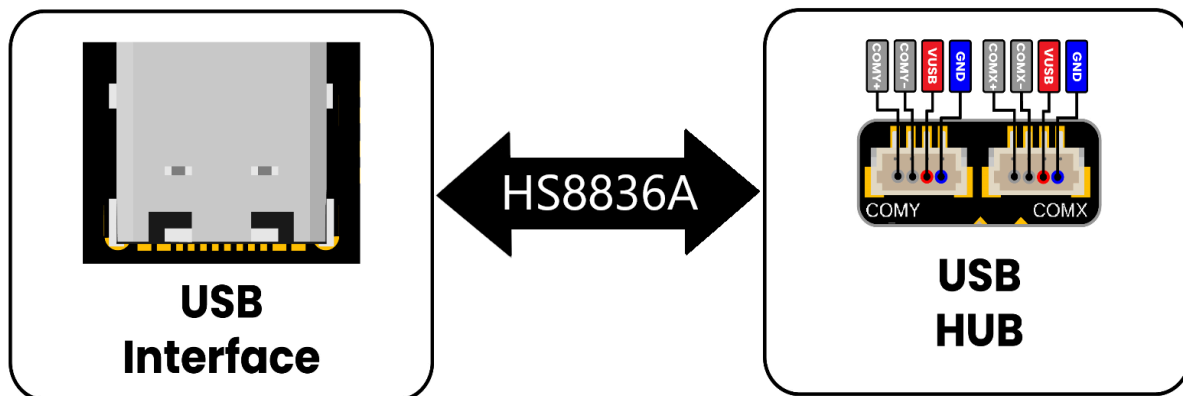

3.12 DIP Switch for UART Communication

The DualMCU-ONE includes a DIP switch (SW1) to facilitate UART communication between the two onboard microcontrollers.

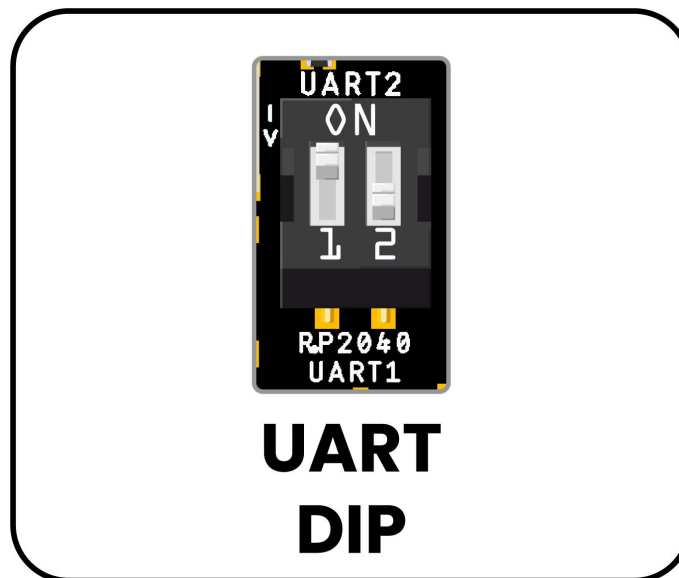

This switch enables the following pin connections:

Table 3.12.1 - UART Pin Mapping via DIP Switch

Microcontroller	UART Pin	DIP Switch Connection	Function
RP2040	Tx (GPIO0)	Connected to Rx (IO16) on ESP32	Transmit Data from RP2040 to ESP32
RP2040	Rx (GPIO1)	Connected to Tx (IO17) on ESP32	Receive Data from ESP32 to RP2040
ESP32	Tx (IO17)	Connected to Rx (GPIO1) on RP2040	Transmit Data from ESP32 to RP2040
ESP32	Rx (IO16)	Connected to Tx (GPIO0) on RP2040	Receive Data from RP2040 to ESP32

By toggling the DIP switch, developers can establish direct UART communication for data transfer and control between the microcontrollers. This setup is especially useful when the ESP32 functions as a co-processor, managing wireless connectivity or CAN BUS communication, while the RP2040 handles other operational tasks. For further details on the location of SW1, refer to **Table 3.2.1 - Components Overview: Front View**.

3.13 SPI Communication Between MCUs (RP2040 and ESP32)

The SPI communication interface between the RP2040 and the ESP32 microcontrollers allows for high-speed data transfer and enhanced reliability in system operations. This communication is crucial for enabling seamless data exchange between the two microcontrollers, ensuring efficient performance in applications requiring concurrent processing by both chips.

Additionally, the ESP32 is fully compatible with the **Arduino NINA firmware**, which facilitates the integration of Wi-Fi and Bluetooth capabilities. The NINA firmware, designed for the **u-blox NINA-W102** module (based on ESP32), provides an easy-to-use API for wireless communication, enabling reliable and robust wireless connectivity in IoT and other communication-focused applications. By leveraging the NINA firmware, you can also extend the ESP32's functionality to manage other system components, such as CAN bus communication, PWM signals, and additional ADC channels beyond what the RP2040 offers. This setup allows the RP2040 to control the ESP32 as an effective co-processor, offloading specific tasks like wireless communication or managing additional peripherals while the RP2040 handles other critical operations.

For detailed information on the pin mappings and connections for SPI communication, refer to **Table 3.13.1**.

Table 3.13.1: SPI Pin Mapping for RP2040 and ESP32 Communication

RP2040 (Master)	Function	ESP32 (Slave)	Function	Arduino UNO Matching ¹
GPIO12	MISO	IO23	MOSI	D24
GPIO13	CS0	IO5	CS0	D25
GPIO14	SCK	IO18	SCK	D26
GPIO15	MOSI	IO14	MISO	D27
GPIO7	BUSY	IO33	BUSY	D23

3.14 Power Tree

The DualMCU-ONE supports dual power input options: it can be powered either through the USB-C port (J1) or via the VIN pin on J2, which accepts a voltage range of 18–20 V (maximum).

Power supply selection is managed by the LMV321 operational amplifier, ensuring seamless switching between sources. If a voltage is present on the VIN pin, it takes priority; otherwise, power is drawn from the USB-C connector.

The VIN input is regulated by the MP1482DS DC/DC converter, which steps down the voltage to provide a stable 5V output at up to 2A of current. A secondary LDO regulator, the NCP117ST33, further converts the 5V supply to 3.3V, delivering up to 800 mA.

This 3.3V rail powers the RP2040 and ESP32 microcontrollers, as well as all other onboard peripherals, ensuring stable and efficient operation throughout the system.

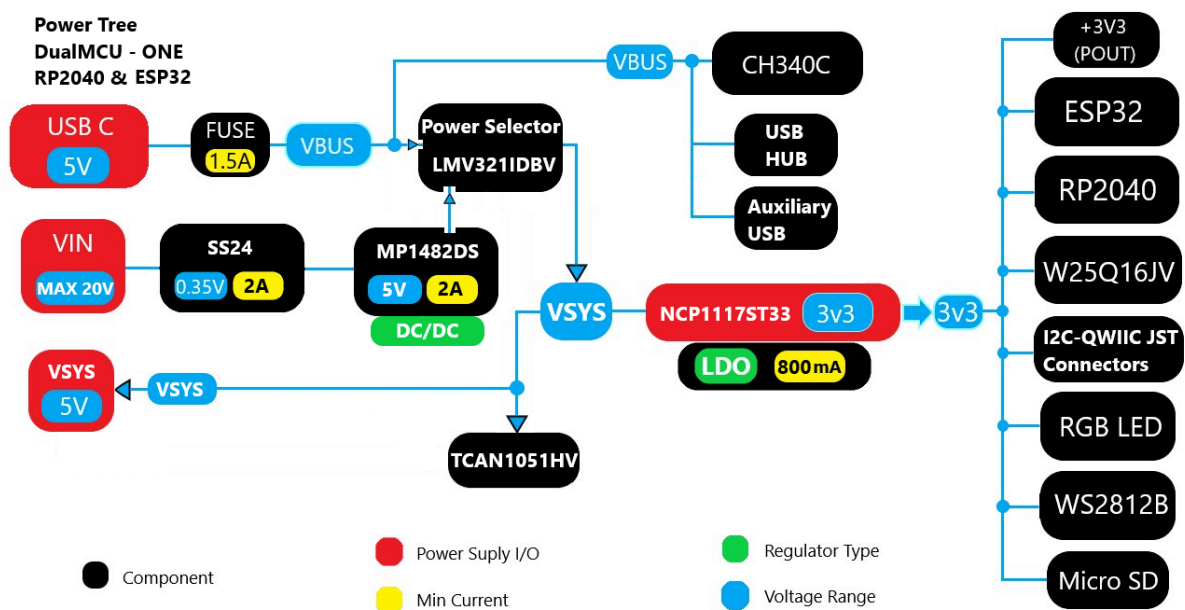

DualMCU-ONE RP2040 & ESP32 Power Tree

4 Connectors & Pinouts

4.1 General Top Side Pinout

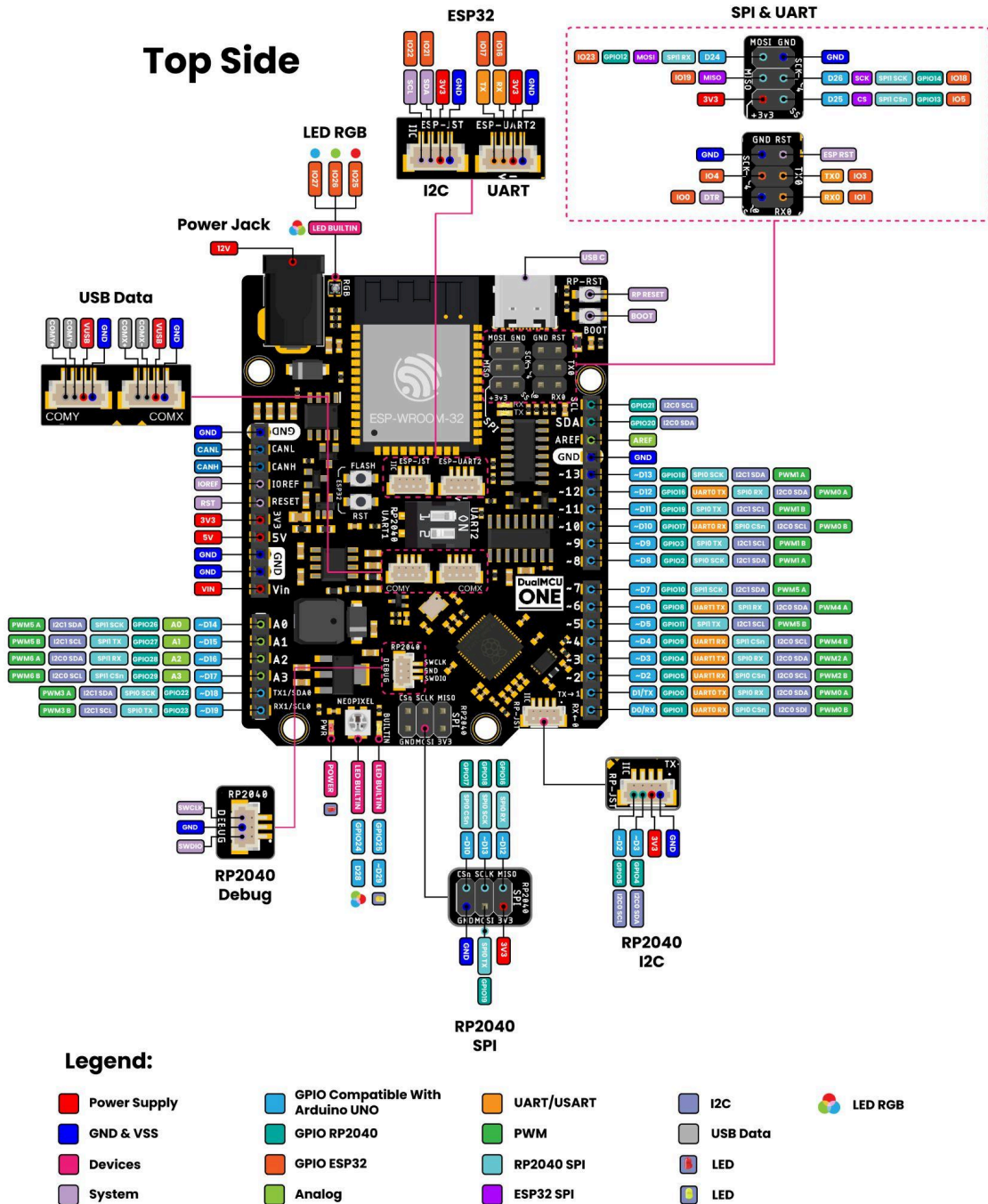

DualMCU-ONE RP2040&ESP32 General TOP Side Pinout

4.2 General Bottom Side Pinout

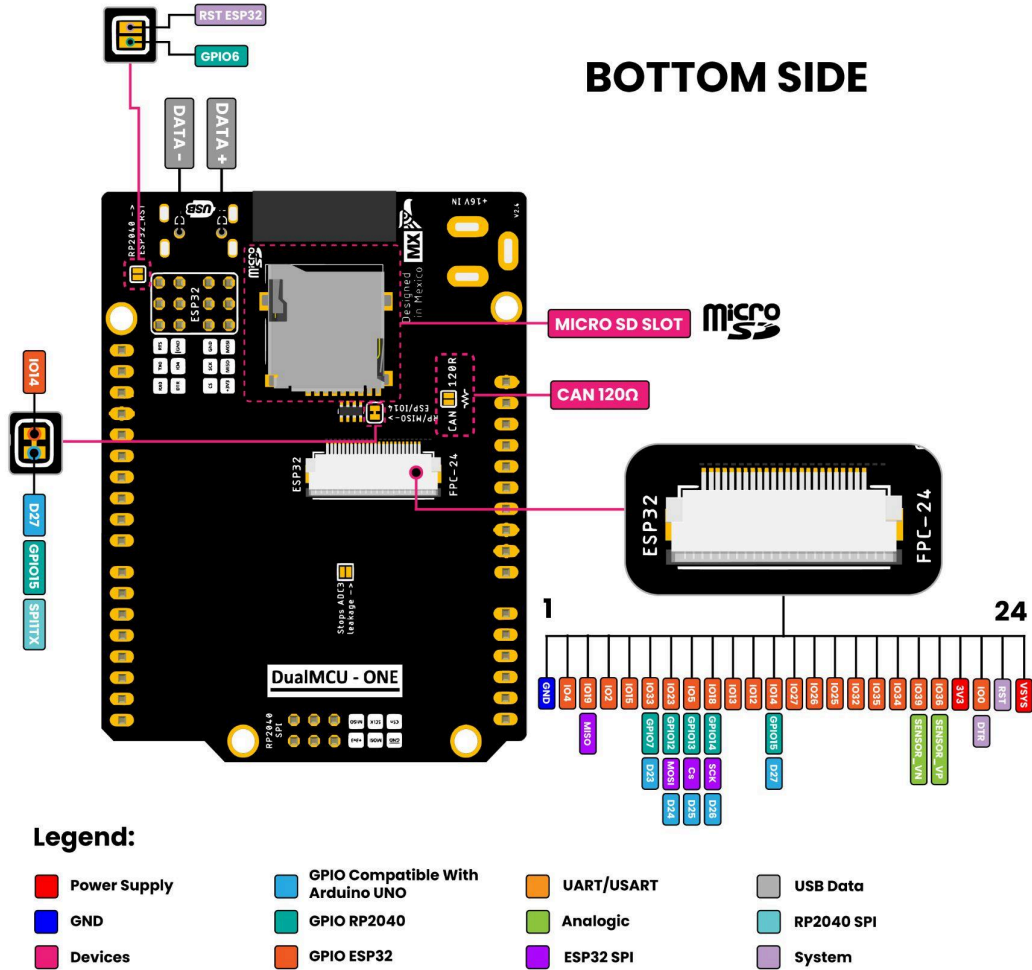

DualMCU-ONE RP2040&ESP32 General BOTTOM Side Pinout

4.3 DualMCU-ONE: Arduino UNO Pinout Compatibility

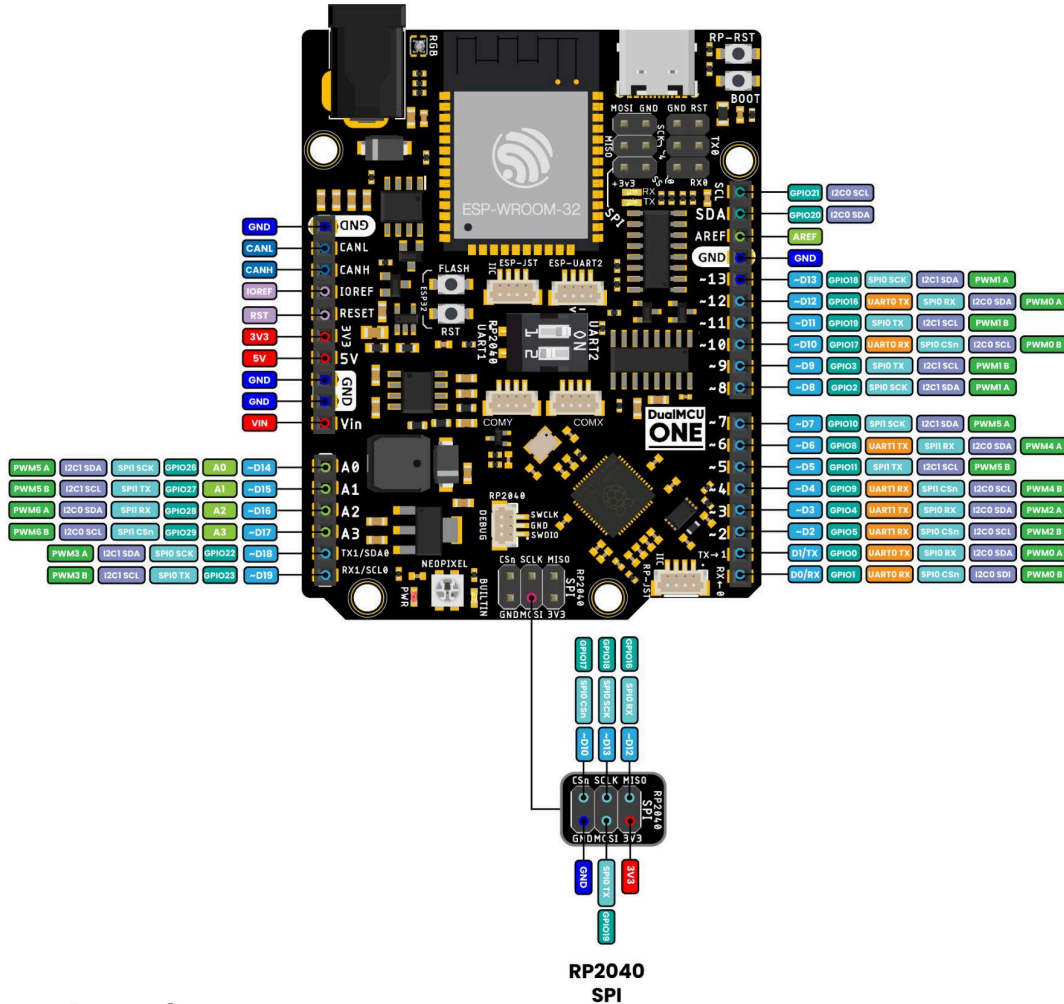

Legend:

- | | | | |
|-------------------------------------------------|---------------------------------------------------------------------------|--------------------------------------------------|-------------------------------------------|
| ■ Power Supply | ■ GPIO Compatible With Arduino UNO | ■ UART/USART | ■ I2C |
| ■ GND & VSS | ■ GPIO RP2040 | ■ PWM | |
| ■ System | ■ Analog | ■ RP2040 SPI | |

Arduino UNO-Compatible Pinout on DualMCU-ONE

Table 4.3.1 - Pin Mapping and Connections for the Arduino UNO-Compatible Pinout (Connections to the RP2040 MCU)

Arduino UNO Function	DualMCU-ONE (RP2040)	RP2040 MCU	Function
-	GND	GND	GND
-	CANL	-	CAN BUS - LOW
-	CANH	-	CAN BUS - HIGH
IOREF	IOREF	+5V/VSYS	+5V/VSYS
RESET	RESET	RUN	RESET/ENABLE
3V3	3V3	+3v3	+3v3
5V	5V	+5V/VSYS	+5V/VSYS
GND	GND	GND	GND
GND	GND	GND	GND
VIN	VIN	-	EXTERNAL POWER SUPPLY
A0/D14	A0/D14	GPIO26	ADC0/SPI1 SCK/ UART1 CTS/ I2C1 SDA/ PWM5 A/ SIO/ PIO0/ PIO1/ USB VBUS EN
A1/D15	A1/D15	GPIO27	ADC1/SPI1 TX/ UART1 RTS/ I2C1 SCL/ PWM5 B/ SIO/ PIO0/ PIO1/ USB OVCCR DET
A2/D16	A2/D16	GPIO28	ADC2/SPI1 RX/UART0 TX/ I2C0 SDA/ PWM6 A/SIO/ PIO0/ PIO1/ USB VBUS DET
A3/D17	A3/D17	GPIO29	ADC3/SPI1 CSn/ UART0 RX/ I2C0 SCL/ PWM6 B/ SIO/ PIO0/ PIO1/ USB VBUS EN
A4/SDA	-	-	-

A5/SCL	-	-	-
D0/RX	D0/RX0	GPIO1/RX0	SPI0 CSn/ UART0 RX/ I2C0 SCL/ PWM0 B/ SIO/ PIO0/ PIO1/ USB VBUS DET
D1/TX	D1/TX0	GPIO0/TX0	SPI0 RX/ UART0 TX/ I2C0 SDA/ PWM0 A/ SIO/ PIO0/ PIO1/ USB OVCCR DET
D2	D2/RX1	GPIO5/RX1/SCL0	SPI0 CSn/ UART1 RX/ I2C0 SCL/ PWM2 B/ SIO/ PIO0/ PIO1/ USB VBUS EN
D3	D3/TX1	GPIO4/TX1/SDA0	SPI0 RX/ UART1 TX/ I2C0 SDA/ PWM2 A/ SIO/ PIO0/ PIO1/ USB VBUS DET
D4	D4	GPIO9/CS1/RX1	SPI1 CSn/ UART1 RX/ I2C0 SCL/ PWM4 B/ SIO/ PIO0/ PIO1/ USB OVCCR DET
D5	D5	GPIO11/MOSI1	SPI1 TX/ UART1 RTS/ I2C1 SCL/ PWM5 B/ SIO/ PIO0/ PIO1/ USB VBUS EN
D6	D6	GPIO8/MISO1	SPI1 RX/ UART1 TX/ I2C0 SDA/ PWM4 A/ SIO/ PIO0/ PIO1/ USB VBUS EN
D7	D7	GPIO10/SCK1	SPI1 SCK/ UART1 CTS/ I2C1 SDA/ PWM5 A/ SIO/ PIO0/ PIO1/ USB VBUS DET
D8	D8	GPIO2/SDA1	SPI0 SCK/ UART0 CTS/ I2C1 SDA/ PWM1 A/ SIO/ PIO0/ PIO1/ USB VBUS EN
D9	D9	GPIO3/SCL1	SPI0 TX/ UART0 RTS/ I2C1 SCL/ PWM1 B/ SIO/ PIO0/ PIO1/ USB OVCCR DET
D10	D10	GPIO17/CS0	SPI0 CSn/ UART0 RX/I2C0 SCL/ PWM0 B/ SIO/ PIO0/ PIO1/ USB VBUS EN
D11	D11	GPIO19/MOSI0	SPI0 TX/ UART0 RTS/ I2C1 SCL/ PWM1 B/ SIO/ PIO0/ PIO1/ USB VBUS DET
D12	D12	GPIO16/MISO0	SPI0 RX/ UART0 TX/ I2C0 SDA/ PWM0 A/ SIO/ PIO0/ PIO1/ USB VBUS DET

D13	D13	GPIO18/SCK0	SPI0 SCK/ UART0 CTS/ I2C1 SDA/ PWM1 A/ SIO/ PIO0/ PIO1/ USB OVCR DET
GND	GND	GND	GND
AREF	AREF	ADC_VREF	ADC_VREF
D18/SDA	D18/SDA_1	GPIO22/SDA0	SPI0 SCK, UART1 CTS, I2C1 SDA, PWM3 A, SIO, PIO0, PIO1, CLOCK GPIN1, USB VBUS DET
D19/SCL	D19/SCL_1	GPIO23/SCL0	SPI0 TX, UART1 RTS, I2C1 SCL, PWM3 B, SIO, PIO0, PIO1, CLOCK GPOUT1, USB VBUS EN
-	D20/SDA_0	GPIO20/SDA0	SPI0 RX/ UART1 TX/ I2C0 SDA/ PWM2 A/ SIO/ PIO0/ PIO1/ CLOCK GPIN0/ USB VBUS EN
-	D21/SCL_0	GPIO21/SCL0	SPI0 CSn/ UART1 RX/ I2C0 SCL/ PWM2 B/ SIO/ PIO0/ PIO1/ CLOCK GPOUT0/ USB OVCR DET
-	D22/ESP_RESET*	GPIO6	SPI0 SCK, UART1 CTS, I2C1 SDA, PWM3 A, SIO, PIO0, PIO1, USB OVCR DET
-	D23/ESP_BUSY	GPIO7	GPIO
-	D24/ESP_MOSI	GPIO12	SPI1 RX
-	D25/ESP_SS	GPIO13	SPI1 CSn
-	D26/ESP_SCK	GPIO14	SPI1 SCK
-	D27/ESP_MISO	GPIO15	SPI1 TX
-	D28/NEOP	GPIO24	Only connected to WS2812B-3030 LED
-	D29/LED_BUILTIN	GPIO25	Only connected to LED_BUILTIN

- **D22 (GPIO6)** is by default disconnected from ESP_RESET; to connect them, you need to solder the pad located on the back of the board.

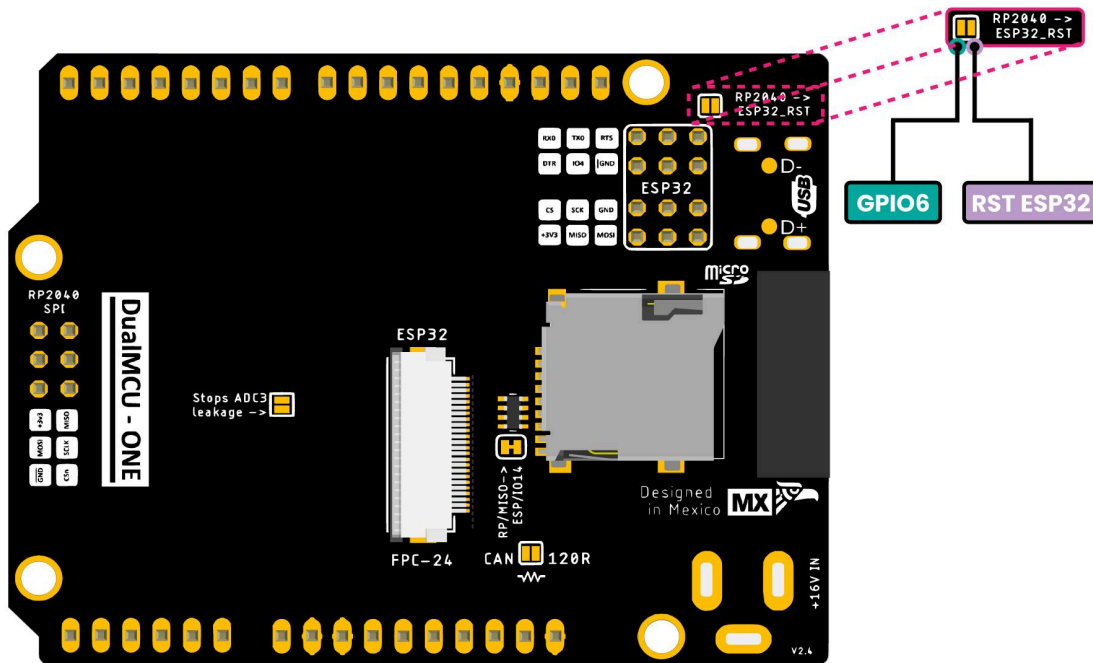

- **D22, D23, D24, D25, D26, and D27** are directly connected to the ESP32 microcontroller and are used for SPI communication between the two microcontrollers. It is important to note that D23 and D27 are only accessible through the FPC-24 connector.
- **D28 and D29** are not available on any connector or header; their control is exclusively limited to the RP2040 microcontroller, They are only connected to the WS2812B-3030 LED and the Built-in LED.

4.4 RP2040 Debugging, QWIIC, and SPI Connectors

RP2040: Debug Connector, I2C- QWIIC Connector, and SPI Connector

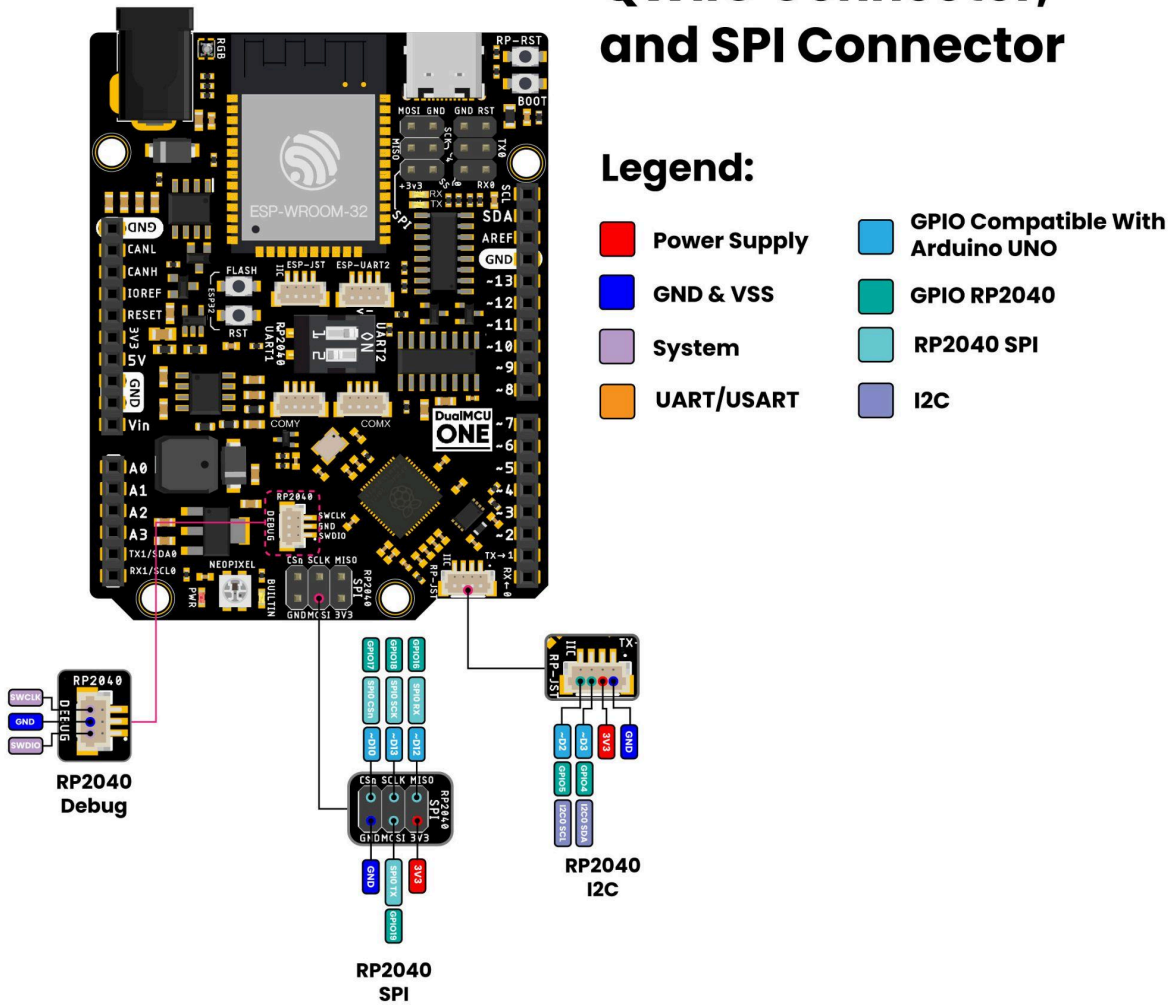

DualMCU-ONE RP2040 Debugging, QWIIC, and SPI Connectors

Table 4.4.1 - RP2040 SPI Header Connector

Pin	RP2040	Function	Arduino UNO Matching
1	GND	GND	-
2	GPIO17	CSn	D10
3	GPIO19	MOSI	D11
4	GPIO18	SCLK	D13
5	+3V3	+3V3	-
6	GPIO16	MISO	D12

Table 4.4.2 - RP2040 Debugging Connector

Pin	RP2040 (UART0)	Function
1	SWDIO	SWDIO
2	GND	GND
3	SWCLK	SWCLK

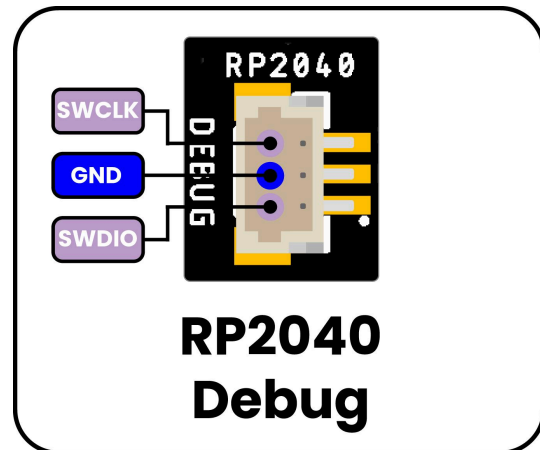
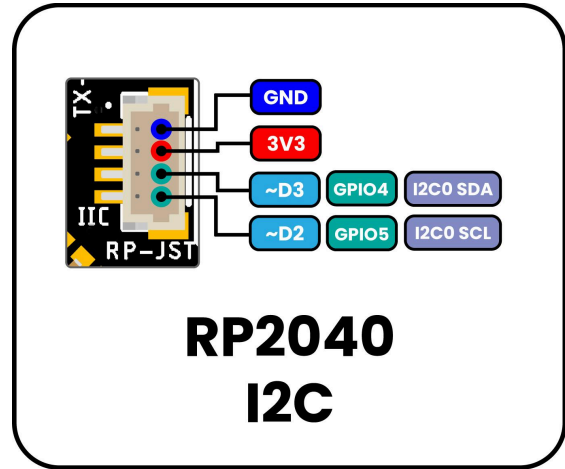

Table 4.4.3 - RP2040 I2C-QWIIC Connector

Pin	RP2040- JST (QWIIC)	Function
1	GND	GND
2	+3V3	+3V3
3	GPIO4	SDA
4	GPIO5	SCL



4.5 ESP32: SPI & UART Headers, I2C-QWIIC, JST-UART and CAN BUS Connectors

ESP32 MCU: Headers, I2C- QWIIC, JST- UART and CAN Bus Connectors

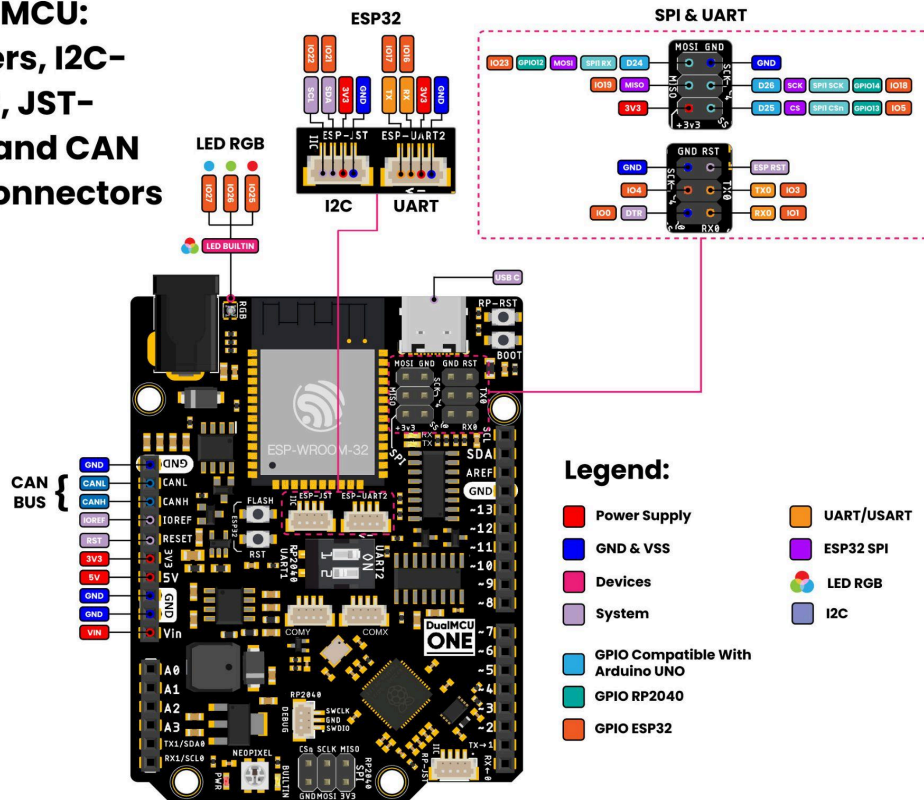

DualMCU-ONE - ESP32 MCU Connectors

Table 4.5.1 ESP32: SYSTEM & UART Header

Pin	ESP32	Function
1	EN	RST/ESP_RESET
2	GND	GND
3	IO3	TX0
4	IO4	4
5	IO1	RX0
6	IO0	DTR/0

Table 4.5.2 ESP32: SPI Header

Pin	ESP32(Master)	Function	Connection to the RP2040 MCU	Arduino UNO Matching ¹
6	GND	GND	GND	-
5	IO23	MOSI	GPIO12	D24
4	IO18	SCK	GPIO14	D26
3	IO19	MISO	-	-
2	IO5	SS	GPIO13	D25
1	+3V3	+3V3	+3V3	-

Notes:

¹ The declaration of the definitions D23, D24, D25, D26, and D27 in Arduino is only useful when selecting the RP2040 microcontroller in the Arduino IDE (Board: UNIT Dual ONE RP2040).

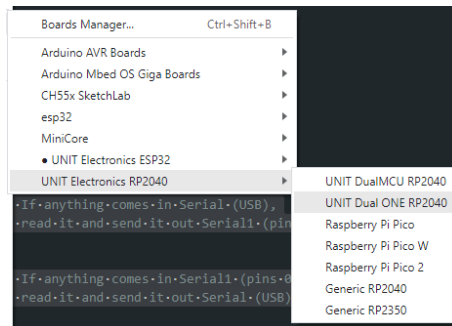

Table 4.5.3 ESP32: I2C-QWIIC & JST-UART

Pin	ESP32 - JST (QWIIC)	Function	ESP32 - JST (UART2)	Function
1	GND	GND	GND	GND
2	+3v3	+3v3	+3v3	+3v3
3	IO21	SDA	IO16	RX1
4	IO22	SCL	IO17	TX2

Table 4.5.4 ESP32: CAN BUS

ESP32 (CAN)	Function
IO25	CAN_TX
IO26	CAN_RX

4.6 ESP32: Auxiliary MicroSD & FPC-24P Connectors

ESP32: Auxiliary MicroSD & FPC-24P Connectors

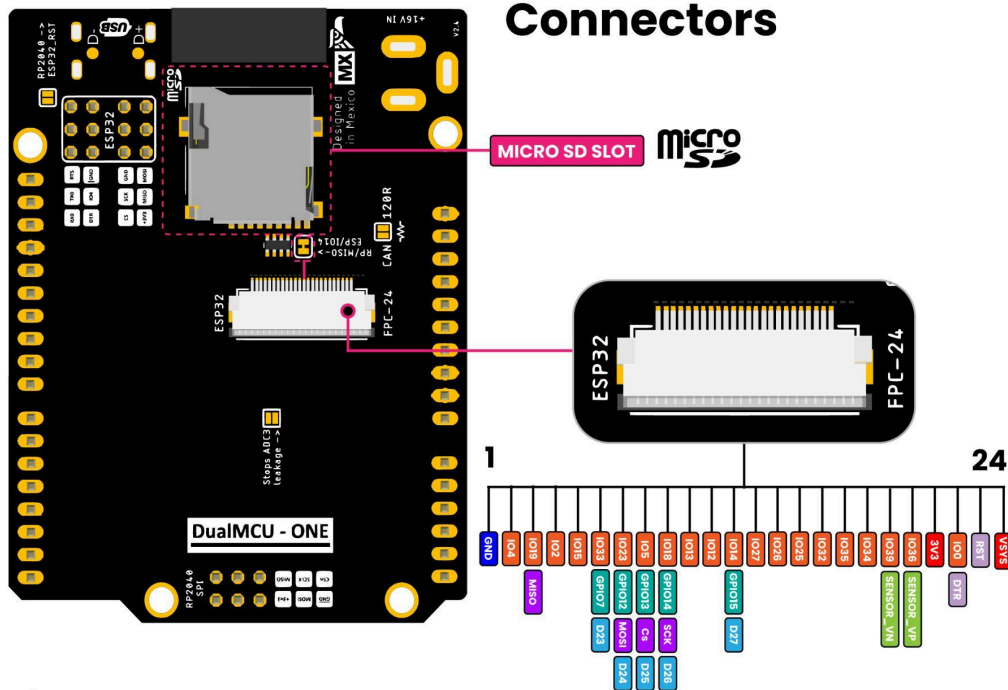

Legend:

- Power Supply
- GPIO Compatible With Arduino UNO
- System
- GND
- GPIO RP2040
- Analogic
- Devices
- GPIO ESP32
- ESP32 SPI

DualMCU-ONE: ESP32 Auxiliary MicroSD & FPC-24P Connectors

Table 4.6.1 ESP32: MicroSD Holder²

ESP32 (GPIO)	MicroSD Pin	MicroSD Function	Connection to the RP2040 MCU	Arduino UNO Matching ¹
IO2	7	DAT0	-	-
IO4	8	DAT1	-	-
IO12	1	DAT2	-	-
IO13	2	CD/DAT3	-	-
IO15	3	CMD	-	-
IO14	5	CLK	GPIO15	D27
GND	6	VSS	GND	-
+3V3	4	VDD	+3V3	-

This socket is directly connected to the ESP32 microcontroller via QSPI communication, offering data transfer speeds up to four times faster than its predecessor, the DualMCU board.

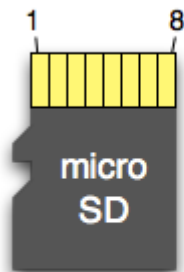

Pin	SD
1	DAT2
2	CD/DAT3
3	CMD
4	VDD
5	CLK
6	VSS
7	DAT0
8	DAT1

MicroSD Pinout

Table 4.6.2 ESP32: Auxiliary FPC-24P Connector³

FPC-24P Pin	ESP32 (GPIO)	Connection to the RP2040 MCU	Arduino UNO Matching ¹
1	GND	-	-
2	IO4	-	-
3	IO19/MISO	-	-
4	IO2	-	-
5	IO15	-	-
6	IO33	GPIO7	D23
7	IO23/MOSI	GPIO12	D24
8	IO5/Cs	GPIO13	D25
9	IO18/SCK	GPIO14	D26
10	IO13	-	-
11	IO12	-	-
12	IO14	GPIO15	D27
13	IO27	-	-
14	IO26	-	-
15	IO25	-	-
16	IO32	-	-
17	IO35	-	-

18	IO34	-	-
19	IO39/SENSOR_VN	-	-
20	IO36/SENSOR_VP	-	-
21	+3V3	-	-
22	IO0/DTR	-	-
23	RST	-	-
24	VSYS	-	-

Notes:

² The MicroSD socket, model **THD2528-11SD-GF**, can be soldered directly onto the bottom side of the board. Please note that this socket is not pre-installed on the DualMCU-ONE board. However, end users can purchase the socket separately and solder it onto the designated pads, offering flexibility for those who wish to utilize this feature.

³ Please note that this **FPC-24P** connector is not pre-installed on the DualMCU-ONE board. This connector can be soldered onto the back of the DualMCU-ONE, providing direct access to most of the ESP32 microcontroller's pins.

4.7 - Auxiliary JST Connectors (1mm Pitch) for USB

USB HUB JST Connectors

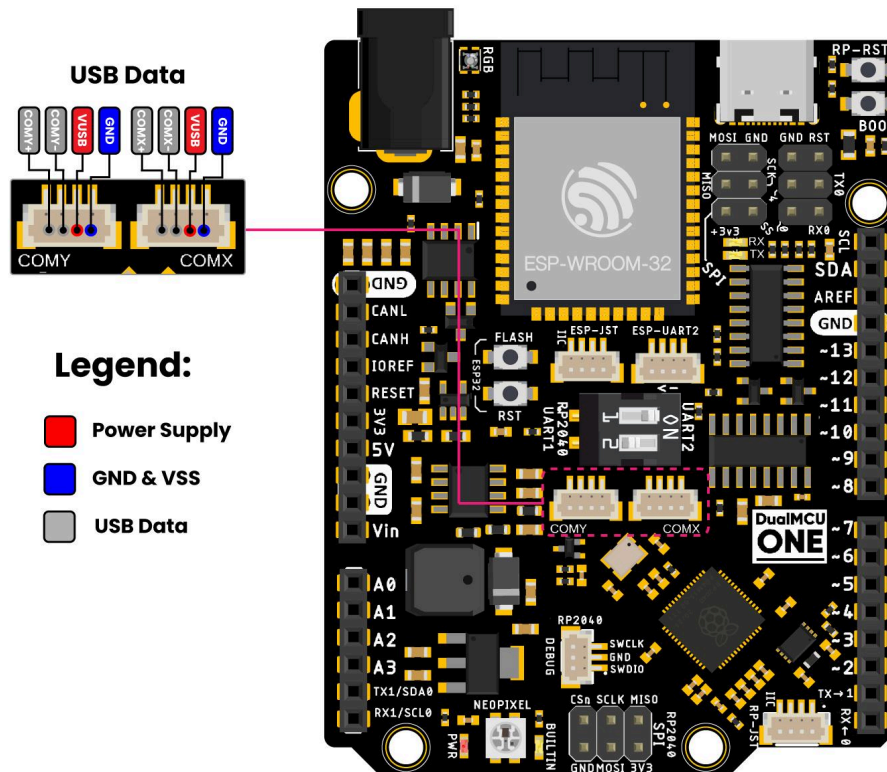

The DualMCU-ONE board includes 1mm pitch JST connectors that provide the capability to connect additional USB devices via the HS8836A USB Type-C hub. These connectors allow for the connection of up to two additional USB-powered devices, using the **JST3** and **JST4** ports. These ports support USB-powered devices such as keyboards, mice, additional development boards, or USB modules, thereby expanding the system's functionality without the need for additional USB ports on the board.

The **JST3** and **JST4** connectors are available on the PCB and are labeled as **COMx** for JST3 and **COMy** for JST4. Each connector follows a standard pinout, with the following pin assignments:

- **Pin 1:** GND (Ground)
- **Pin 2:** VUSB (Power)
- **Pin 3:** D- (Data -)
- **Pin 4:** D+ (Data +)

It is important to note that the power for these connectors comes directly from the **VUSB** pin, which is protected by a 1.2A fuse. Therefore, it is essential to consider the power consumption of the devices connected to these ports to avoid exceeding the load allowed by the fuse, ensuring safe and stable operation of the system.

The following tables detail the pinout for the **JST3** and **JST4** connectors, along with their respective pin connections.

Table 4.7.1 - JST3 (COMx) Connector Pinout

Pin	Description	Connection
1	GND	Ground
2	VUSB	Power
3	D-	Data -
4	D+	Data +

Table 4.7.2 - JST4 (COMY) Connector Pinout

Pin	Description	Connection
1	GND	Ground
2	VUSB	Power
3	D-	Data -
4	D+	Data +

For further details on the location of the JST connectors on the PCB, refer to **Section 4.1**, as well as the electrical schematic at the end of this document. The schematic provides a clear overview of the electrical connections on the PCB.

5 Board Operation

5.1 Getting Started with arduino IDE

To configure the **DualMCU-ONE** in the Arduino IDE (version 2.0 or higher), follow these steps:

Adding the UNIT Electronics Boards Package

1. **Open Preferences:**
 - Go to the **File** menu and select **Preferences** (or **Settings** on some systems).
2. **Add Board Manager URLs:**
 - In the **Additional Board Manager URLs** field, add the following links:

- **RP2040 JSON URL:**

```
https://raw.githubusercontent.com/UNIT-Electronics/Uelectronics-RP2040-Arduino-Package/main/package_Uelectronics_rp2040_index.json
```

- **ESP32 JSON URL:**

```
https://raw.githubusercontent.com/UNIT-Electronics/Uelectronics-ESP32-Arduino-Package/main/package_Uelectronics_esp32_index.json
```

- Click **OK** to save.

3. **Tip:** If there are multiple URLs to add, separate them with commas.

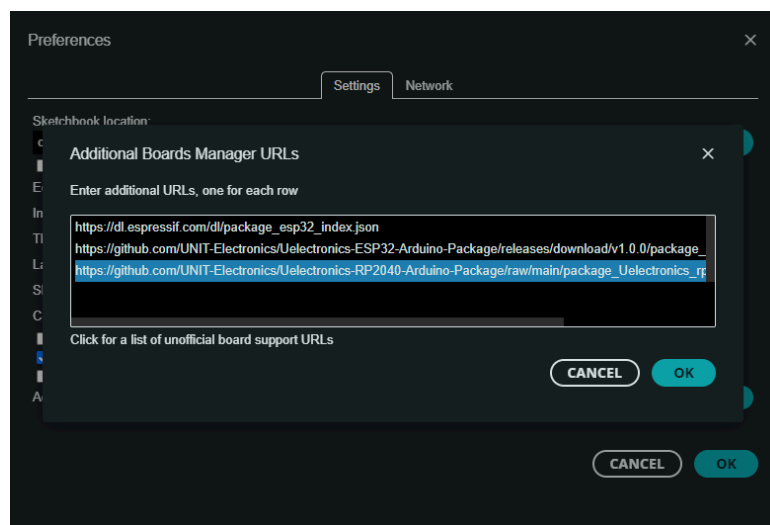

Installing the Board Packages

Open Board Manager:

- Navigate to **Tools > Board > Board Manager**.

Search for UNIT Electronics Boards:

- In the search bar, type **UNIT Electronics RP2040** or **UNIT Electronics ESP32**.

Install the Latest Version:

- Select the latest available version of the desired package and click **Install**.

Note: Ensure you have an active internet connection during this step.

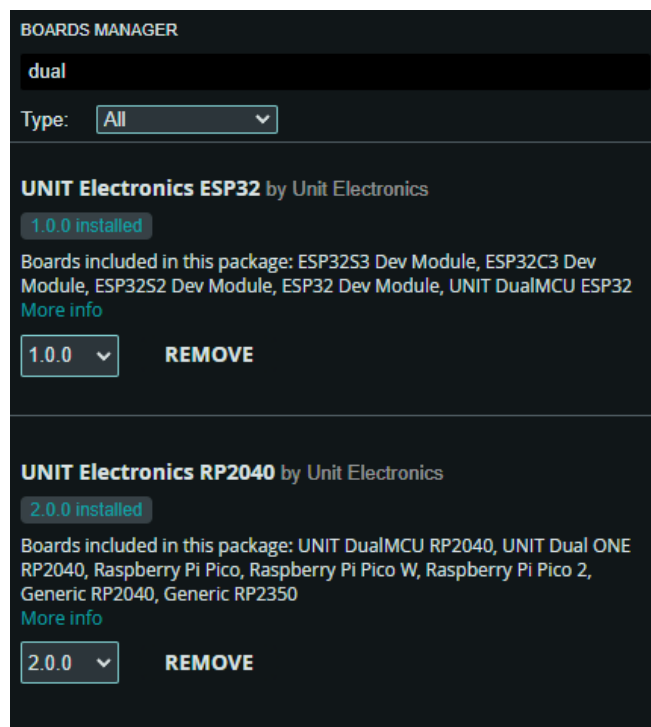

Selecting the Board

6. Set Your Board:

- Go to **Tools > Board**, and select the **UNIT Electronics RP2040** or **UNIT Electronics ESP32** category, depending on the microcontroller you want to program. Once inside the selected category, choose the **DualMCU-ONE** board.

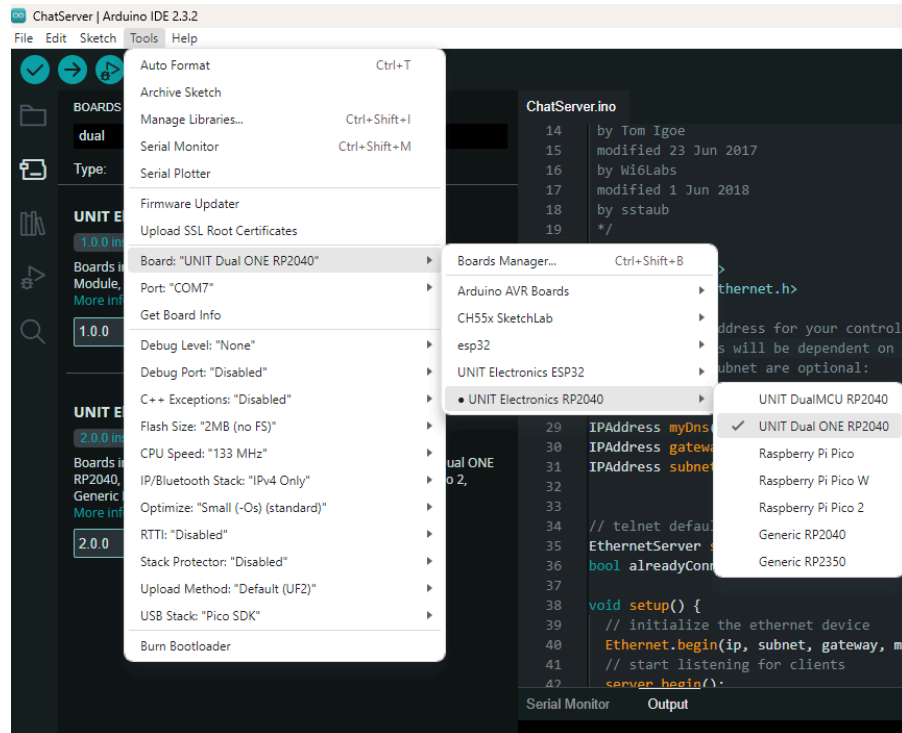

7. Connect the Board:

- Use a USB Type-C cable to connect the DualMCU-ONE to your computer. Ensure the correct port is selected under **Tools > Port**.

By completing these steps, you'll be ready to start programming your **DualMCU-ONE** using Arduino IDE.

6 Mechanical Information

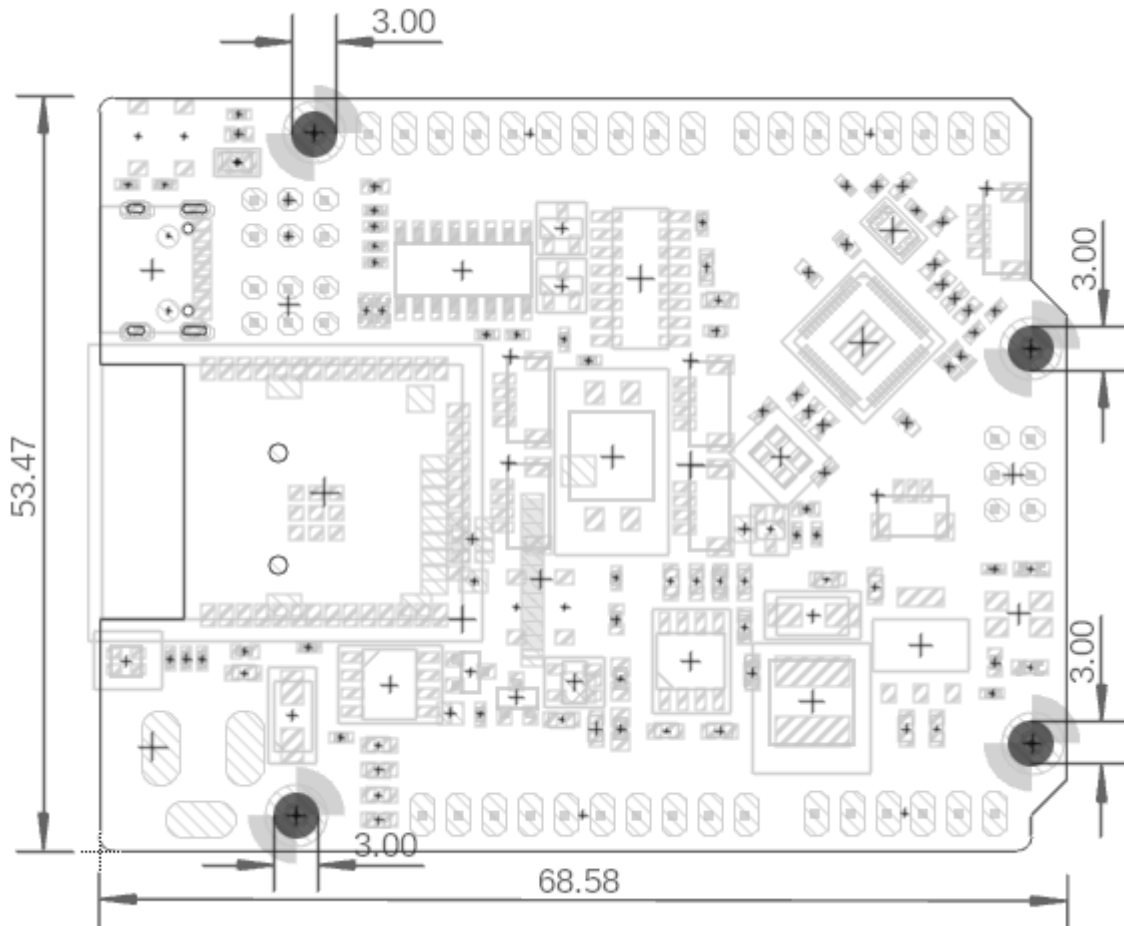

Mechanical dimensions of DualMCU-ONE RP2040 + ESP32

7 Company Information

Company name	UNIT Electronics
Company website	https://uelectronics.com/
Company Address	Salvador 19, Cuauhtémoc, 06000 Mexico City, CDMX

8 Reference Documentation

Ref	Link
UNIT DualMCU-ONE Documentation	https://github.com/UNIT-Electronics/DualMCU-ONE
UNIT DualMCU-ONE RP2040 Arduino Package	https://github.com/UNIT-Electronics/Uelectronics-RP2040-Arduino-Package
UNIT DualMCU-ONE ESP32 Arduino Package	https://github.com/UNIT-Electronics/Uelectronics-ESP32-Arduino-Package
Getting started with DualMCU-ONE	https://unit-electronics.github.io/DualMCU-ONE/index.html
Thonny IDE	https://thonny.org/
Arduino IDE	https://www.arduino.cc/en/software
CH340 Driver	http://www.wch-ic.com/downloads/CH341SER_ZIP.html
Visual Studio Code	https://code.visualstudio.com/download
Raspberry Pi Pico RP2040 Documentation	https://www.raspberrypi.com/documentation/microcontrollers/
Raspberry Pi Pico Python SDK	https://datasheets.raspberrypi.com/pico/raspberry-pi-pico-python-sdk.pdf
raspberrypi/pico-micropython-examples	https://github.com/raspberrypi/pico-micropython-examples
Raspberry Pi Pico C/C++ SDK	https://www.raspberrypi.com/documentation/microcontrollers/c_sdk.html
raspberrypi/pico-C/C+-examples	https://github.com/raspberrypi/pico-examples
RP2040 Datasheet	https://datasheets.raspberrypi.com/rp2040/rp2040-datasheet.pdf
ESP32 WROOM 8MB	https://www.espressif.com/sites/default/files/documentation/esp32-wroom-32e_esp32-wroom-32ue_datasheet_en.pdf

9 Appendix

9.1 Schematic (https://github.com/UNIT-Electronics/DualMCU-ONE/blob/main/Hardware/UE0022_DualMCU-ONE_v2.4_Schematic.pdf)

